

Metrics of positive Ricci curvature on simply-connected manifolds of dimension $6k$

Philipp Reiser 

Institut für Algebra und Geometrie,
Karlsruher Institut für Technologie (KIT),
Germany

Correspondence

Philipp Reiser, Department of
Mathematics, University of Fribourg,
Fribourg, Switzerland.
Email: philipp.reiser@unifr.ch

Funding information

Deutsche Forschungsgemeinschaft,
Grant/Award Number: 281869850 (RTG
2229)

Abstract

A consequence of the surgery theorem of Gromov and Lawson is that every closed, simply-connected 6-manifold admits a Riemannian metric of positive scalar curvature. For metrics of positive Ricci curvature, it is widely open whether a similar result holds; there are no obstructions known for those manifolds to admit a metric of positive Ricci curvature, while the number of examples known is limited. In this article, we introduce a new description of certain $6k$ -dimensional manifolds via labeled bipartite graphs and use an earlier result of the author to construct metrics of positive Ricci curvature on these manifolds. In this way, we obtain many new examples, both spin and nonspin, of $6k$ -dimensional manifolds with a metric of positive Ricci curvature.

MSC 2020

53C20, 57R65 (primary)

1 | INTRODUCTION AND MAIN RESULTS

Determining which manifolds admit a complete Riemannian metric of positive Ricci curvature remains a long-standing open problem. In this article, we consider this problem for closed and simply-connected manifolds. Under this assumption, the only known obstructions for the existence of a Riemannian metric of positive Ricci curvature already vanish for the (potentially) weaker condition of positive scalar curvature. In particular, it is an open question whether any

closed, simply-connected manifold with a Riemannian metric of positive scalar curvature also admits a Riemannian metric of positive Ricci curvature.

When considering low dimensions, the first nontrivial case is dimension 4 as any closed, simply-connected manifold in dimensions 2 and 3 is a standard sphere. Here, it was shown by Sha and Yang [26] that any closed, simply-connected 4-manifold that admits a metric with positive scalar curvature is homeomorphic to a manifold with positive Ricci curvature, and in particular completely classified the intersection forms that can be realized by such a manifold. Further, in dimension 5, Sha and Yang [25] proved that any closed, simply-connected 5-manifold with torsion-free homology admits a metric of positive Ricci curvature by constructing such metrics on connected sums of sphere bundles over spheres. In this article, we consider dimension 6 and construct new examples of closed, simply-connected 6-manifolds with torsion-free homology that admit a metric of positive Ricci curvature. Moreover, we extend our construction to all dimensions $6k$, $k \in \mathbb{N}$.

As a result of the surgery theorem of Gromov and Lawson [10], any closed, simply-connected 6-manifold admits a metric of positive scalar curvature. For positive Ricci curvature, while there is no obstruction known for the existence of metrics with this curvature condition, there are only relatively few known examples, see [20, Section 5.1]. In particular, the only examples where we have arbitrarily large Betti numbers are connected sums of sphere bundles.

The main tool to construct metrics of positive Ricci curvature will be the theorem below. It constructs so-called *core metrics*, a notion introduced by Burdick [4]. The main property of a core metric is that it has positive Ricci curvature and that the connected sum of manifolds with core metrics admits a metric of positive Ricci curvature, see Subsection 2.1 below.

Theorem 1.1 [20, Theorem B]. *Let W be the manifold obtained by plumbing linear disc bundles $\overline{E}_i \rightarrow B_i$, $1 \leq i \leq k$, with compact base manifolds according to a simply-connected graph. If all B_i admit a core metric with $\dim(B_i) \geq 3$ and the fiber dimension of \overline{E}_1 is at least 4, then ∂W admits a core metric.*

To state our result, given a closed, simply-connected and oriented $6k$ -dimensional manifold M with torsion-free homology, we have a symmetric trilinear form $\mu_M : H^{2k}(M) \times H^{2k}(M) \times H^{2k}(M) \rightarrow \mathbb{Z}$ defined by

$$\mu_M(x, y, z) = \langle x \smile y \smile z, [M] \rangle.$$

Further invariants we will consider are the k th power of the second Stiefel–Whitney class

$$w_2(M)^k \in H^{2k}(M; \mathbb{Z}/2) \cong H^{2k}(M) \otimes \mathbb{Z}/2$$

and the k th Pontryagin class

$$p_k(M) \in H^{4k}(M) \cong \text{Hom}(H^{2k}(M), \mathbb{Z}).$$

In particular, these invariants are all defined on the cohomology group $H^{2k}(M)$. For $k = 1$, by the classification of Jupp [13], see also Theorem 4.1, these invariants already determine the diffeomorphism type of M up to connected sums with copies of $S^3 \times S^3$. Given a finitely generated free abelian group H , a symmetric trilinear form μ on H , an element $w \in H \otimes \mathbb{Z}/2$, and a linear

form p on H , we call the system (H, μ, w, p) *admissible in dimension $6k$* , if it can be realized as the invariants of a closed, simply-connected $6k$ -dimensional manifold with torsion-free homology.

Let $G = (U, V, E, (\alpha, k^+, k^-))$ be a bipartite graph, where U and V are the sets of vertices and $E \subseteq U \times V$ is the set of edges, with a labeling $(\alpha, k^+, k^-) : U \rightarrow \mathbb{Z} \times \mathbb{N}_0^2$ for vertices in U . We call such a graph an *algebraic plumbing graph*. We draw vertices $u \in U$ as follows:



If one of $k^+(u)$ and $k^-(u)$ vanishes, then we will omit it. Vertices in V will simply be drawn as dots. An example for such a graph is given as follows:

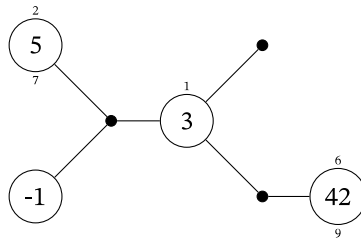

By assigning a suitable disc bundle to each vertex of an algebraic plumbing graph G , we will define for each $k \in \mathbb{N}$ a geometric plumbing graph, denoted as \overline{G}^k , see Definition 4.4 (and note that for $k > 2$, there can be multiple such graphs, see Remark 4.5), which, in turn, defines a $6k$ -dimensional manifold $M_{\overline{G}^k}$, see Definition 3.1. Important invariants, such as the cohomology group $H^{2k}(M_{\overline{G}^k})$, the trilinear form $\mu_{M_{\overline{G}^k}}$, and characteristic classes can be computed directly from the data provided by the algebraic plumbing graph if it is simply-connected. For example, if no vertex in V is a leaf, then $H^{2k}(M_{\overline{G}^k})$ has rank $|U| - |V|$ and $M_{\overline{G}^k}$ is spin if and only if $k^- = k^+ \equiv 0$. The fact that the invariants can be obtained from the graph data if G is simply-connected motivates defining invariants $(H_G, \mu_G^k, w_G, p_G^k)$ in a similar way for any algebraic plumbing graph G , see Definition 4.2. We set $\mu_G = \mu_G^1$ and $p_G = p_G^1$.

Theorem A. *Let G be an algebraic plumbing graph.*

- (1) *If $k = 1$, then the system of invariants (H_G, μ_G, w_G, p_G) is admissible in dimension 6.*
- (2) *If every connected component of G is simply-connected, then the system of invariants $(H_G, \mu_G^k, w_G, p_G^k)$ is admissible in dimension $6k$ and realized by the manifold $M_{\overline{G}^k}$. Further, $M_{\overline{G}^k}$ admits a core metric.*
- (3) *If $k = 1$ and every connected component of G is simply-connected, then any closed, simply-connected 6-manifold with torsion-free homology, whose invariants are equivalent to (H_G, μ_G, w_G, p_G) , admits a core metric.*

Since different algebraic plumbing graphs can have equivalent systems of invariants, it is not clear a priori, how large the class of manifolds is that we obtain in this way. To analyze this further, we introduce a reduced form in Subsection 4.3 and conjecture that systems of invariants obtained

from different reduced forms are indeed not equivalent, see Question 4.10. The difficulty lies in the problem that, in general, it is hard to determine whether two given trilinear forms are equivalent or not. We prove the conjecture for graphs G with $\text{rank}(H_G) \leq 2$, see Propositions 3.3 and 3.5, except for the case where $\text{rank}(H_G) = 2$ and $w_G = 0$ where we obtain a partial result by using invariant theory of $\text{SL}(2, \mathbb{C})$. This result is sufficient to show that infinitely many of the graphs in the latter case define new examples of 6-manifolds with a metric of positive Ricci curvature and of 6-manifolds with core metrics, see Remark 4.18. An interesting subfamily of these graphs is given by certain graphs for which the corresponding 6-manifolds split as a connected sum where one of the summands is a homotopy $\mathbb{C}P^3$, see Proposition 4.20.

For larger Betti numbers, using Theorem A, we have the following result.

Theorem B. *For every $k \in \mathbb{N}$ and for every odd $l \in \mathbb{N}$ sufficiently large, there exists an infinite family M_j^{6k} of pairwise nondiffeomorphic closed $6k$ -dimensional manifolds with torsion-free homology with the following properties:*

- M_j is $(2k - 1)$ -connected with $b_{2k}(M_j) = l$,
- M_j does not split nontrivially as a connected sum,
- M_j is not diffeomorphic to the total space of a linear sphere bundle, a homogeneous space, a biquotient, a cohomogeneity one manifold, or a Fano variety,
- M_j admits a core metric.

Further, if $k = 1$ or k is even, then we can replace the condition that M_j is $(2k - 1)$ -connected by M_j being simply-connected and nonspin.

It follows that the manifolds M_j^6 are new examples of manifolds with a metric of positive Ricci curvature and, to the best of our knowledge, this also holds for the manifolds M_j^{6k} .

This article is organized as follows. In Section 2, we recall core metrics and establish basic results on the topology of certain linear sphere bundle. We proceed in Section 3 by considering plumbing graphs and the topology of the resulting manifolds. Finally, in Section 4, we consider applications in dimension $6k$. Here, we introduce the concept of algebraic plumbing graphs and give the proof of Theorem A in Subsection 4.2. In Subsection 4.3, we consider reduced forms for algebraic plumbing graphs and give applications in Subsection 4.4. In the Appendix, we recall basic facts about the adjacency and incidence matrix of a directed graph needed in Section 3.

2 | PRELIMINARIES

All manifolds and maps between manifolds will be assumed to be smooth. For a manifold M , we will write M^n to indicate that M has dimension n . By D^n , we denote the closed n -dimensional disc and by $M \setminus D^n$ the manifold M with *some* embedded disc removed, where we require the embedding to be orientation preserving if M is oriented. If M is connected, then the embedding is unique up to isotopy, see [17, Theorem 5.5], so the expression $M \setminus D^n$ is well defined up to diffeomorphism. If M is oriented, then $-M$ denotes M with the reversed orientation. If M is oriented and has nonempty boundary, we use the convention that the induced orientation on ∂M is obtained by inserting the inward normal ν first, that is, a basis of tangent vectors (e_1, \dots, e_{n-1}) tangent to ∂M is oriented in ∂M if $(\nu, e_1, \dots, e_{n-1})$ is oriented in M . If not stated otherwise, we use homology and cohomology with coefficients in \mathbb{Z} . We will use the convention that $0 \notin \mathbb{N}$ and set $\mathbb{N}_0 = \mathbb{N} \cup \{0\}$.

For a closed, oriented, and connected manifold M^n , we have $H_n(M; \mathbb{Z}) \cong \mathbb{Z}$ and $H_{n-1}(M; \mathbb{Z}) \cong H^1(M; \mathbb{Z})$ is torsion-free, hence, by the universal coefficient theorem, for a commutative ring R ,

$$H_n(M; R) \cong H_n(M; \mathbb{Z}) \otimes R \cong R.$$

It follows that we obtain a fundamental class $[M; R] \in H_n(M; R)$ from the orientation class $[M; \mathbb{Z}] \in H_n(M; \mathbb{Z})$, which induces an orientation of M in the homological sense with coefficients in R . In particular, Poincaré duality with coefficients in R can be applied for M .

2.1 | Core metrics

In this section, we introduce core metrics. We refer to the work of Burdick [3–6] and the author [20] for further details.

Definition 2.1 (Burdick [4], based on work by Perelman [18]). Let M^n be a manifold. A Riemannian metric g on M is called a *core metric* if it has positive Ricci curvature and if there is an embedding $\varphi : D^n \hookrightarrow \text{Int}(M)$ such that the induced metric $g|_{\varphi(S^{n-1})}$ is the round metric of radius 1 and such that the second fundamental form $\Pi_{\varphi(S^{n-1})}$ is positive semidefinite with respect to the inward pointing normal vector of $S^{n-1} \subseteq D^n$.

Our definition differs from Burdick’s original definition, as he requires the second fundamental form to be positive definite. However, the two definitions are equivalent: a metric with positive semidefinite second fundamental form can always be deformed into a metric with positive definite fundamental form while keeping the Ricci curvature positive, for example, by a deformation as in [3, Proposition 1.2.11].

There exist different sign conventions for the second fundamental form, here we use the sign convention so that, after possibly rescaling the metric, the round metric on S^n is a core metric, where the embedded disc can be any geodesic ball that contains a hemisphere.

The main interest for core metrics comes from the following fact.

Theorem 2.2 [4, Theorem B]. *Let M_i^n , $1 \leq i \leq k$ be manifolds that admit core metrics. If $n \geq 4$, then $\#_i M_i$ admits a metric of positive Ricci curvature.*

So far, the following closed manifolds are known to admit a core metric:

- S^n , if $n \geq 2$,
- the complex projective space $\mathbb{C}P^n$, the quaternionic projective space $\mathbb{H}P^n$ and the Cayley plane $\mathbb{O}P^2$ (see [18] and [4]),
- $M_1^n \# M_2^n$, if $n \geq 4$ and M_1, M_2 admit core metrics (see [6]),
- total spaces of linear S^p -bundles $E^n \rightarrow B^q$ if B admits a core metric and $n \geq 6, p, q \geq 2$ (see [5] and [20]),
- the manifolds obtained in Theorem 1.1.

2.2 | Linear sphere bundles

Let $E \xrightarrow{\pi} B^q$ be a fiber bundle with fiber F^p and structure group G . We suppose that π is oriented, that is, the manifold F is oriented and the action of G on F is orientation-preserving. If the base B

is oriented, then the product orientation on every local trivialization $U \times F$, $U \subseteq B$ open, induces an orientation on the total space E .

If F has nonempty boundary and B has no boundary, then $\partial E \xrightarrow{\pi|_{\partial E}} B$ is a fiber bundle with fiber ∂F and structure group G . We have two orientations on ∂E : The induced orientation from E as a boundary and the induced orientation from B and ∂F when viewed as a fiber bundle. It can be seen in local trivializations that these two orientations coincide if and only if q is even.

We will be interested in the case where $F = D^p$ and $G = \text{SO}(p)$ acts linearly. Then, $\partial F = S^{p-1}$. These bundles are called *linear disc bundles* and *linear sphere bundles*, respectively. In the following, if $E \xrightarrow{\pi} B$ is a linear sphere bundle, we denote by $\bar{E} \xrightarrow{\pi} B$ its corresponding disc bundle. In particular, $\partial \bar{E} = E$.

Let $E \xrightarrow{\pi} B^q$ be an oriented linear sphere bundle with fiber S^{p-1} and connected base B . To describe the cohomology ring of E , we fix a commutative ring R (which we assume to be unital). To simplify notation, when no coefficients for (co-)homology are indicated, we assume in this section that the coefficient ring is given by R . We denote by $\rho_R : H^*(-; \mathbb{Z}) \rightarrow H^*(-)$ the map induced by the ring homomorphism $\mathbb{Z} \rightarrow R$, $z \mapsto z \cdot 1_R$.

Let $e(\pi) \in H^p(B; \mathbb{Z})$ be the Euler class of the bundle π (see, e.g., [15, Chapter 9] for its definition) and set $e_R(\pi) = \rho_R(e(\pi)) \in H^p(B)$. Then we have a long exact sequence, called the *Gysin sequence*,

$$\dots \xrightarrow{\cdot \smile e_R(\pi)} H^i(B) \xrightarrow{\pi^*} H^i(E) \xrightarrow{\psi} H^{i-p+1}(B) \xrightarrow{\cdot \smile e_R(\pi)} H^{i+1}(B) \xrightarrow{\pi^*} \dots, \tag{2.1}$$

see, for example, [15, Corollary 12.2] for $R = \mathbb{Z}$ and note that the proof carries over in the same way for arbitrary R (see also [19, Lemma B.3.1]). The map ψ is defined by

$$\psi = \Phi^{-1} \circ \delta, \tag{2.2}$$

where $\Phi = \cdot \smile u_R(\pi) : H^{*-p}(B) \rightarrow H^*(\bar{E}, E)$ is the Thom isomorphism and $u_R(\pi) \in H^p(\bar{E}, E)$ is the Thom class, and $\delta : H^{*-1}(E) \rightarrow H^*(\bar{E}, E)$ is the connecting homomorphism in the long exact sequence in cohomology for the pair (\bar{E}, E) .

Now assume that the Euler class $e_R(\pi)$ vanishes, so we obtain from the Gysin sequence short exact sequences

$$0 \longrightarrow H^i(B) \xrightarrow{\pi^*} H^i(E) \xrightarrow{\psi} H^{i-p+1}(B) \longrightarrow 0. \tag{2.3}$$

As in [20, Section 5.3], for any $a \in H^{p-1}(E)$ that maps to $1 \in R \cong H^0(B)$ under ψ , we obtain by [14, Lemma 1] a splitting $\theta_a : H^*(B) \rightarrow H^{*+p-1}(E)$ of (2.3) defined by

$$\theta_a(x) = (-1)^{ip} a \smile \pi^*(x)$$

for $x \in H^i(B)$. Hence, we have

$$H^i(E) = \pi^*(H^i(B)) \oplus \theta_a(H^{i-p+1}(B)). \tag{2.4}$$

It follows from (2.2) that $u_R = \Phi(1) = \delta(a)$. Hence, since the Thom class satisfies

$$\bar{t}^* u_R = [D^p, S^{p-1}]^* \tag{2.5}$$

for any fiber inclusion $\bar{\iota}: D^p \hookrightarrow \bar{E}$, it follows that

$$\bar{\iota}^* a = [S^{p-1}]^* \tag{2.6}$$

for any fiber inclusion $\iota: S^{p-1} \hookrightarrow E$.

Remark 2.3. The Thom class u_R is uniquely determined by the property (2.5), see, for example, [15, Theorem 10.4]. For linear sphere bundles we see that, while a satisfies the corresponding property (2.6), it is not uniquely determined by it as the choice of a is not unique, provided that the map $\pi^*: H^{p-1}(B) \rightarrow H^{p-1}(E)$ is nontrivial.

To determine the cohomology ring structure of E , if p is odd, two characteristic classes are important: The Stiefel–Whitney class $w_{p-1}(\pi) \in H^{p-1}(B; \mathbb{Z}/2)$ and the Pontryagin class $p_i(\pi) \in H^{4i}(B; \mathbb{Z})$ for $i = \frac{2p-2}{4}$. As a consequence of the Wu formula for the bundle π , see, for example, [27, Theorem C], we have

$$\mathcal{P}_2(w_{p-1}(\pi)) \equiv p_i(\pi) \pmod{4}, \tag{2.7}$$

where $\mathcal{P}_2: H^j(B; \mathbb{Z}/2) \rightarrow H^{2j}(B; \mathbb{Z}/4)$ is the Pontryagin square operation.

Proposition 2.4. *Let $E \xrightarrow{\pi} B$ be an oriented linear sphere bundle with fiber S^{p-1} , p odd, whose Euler class $e_R(\pi) \in H^p(B; R)$ vanishes and assume that B is connected. Let $W \in H^{p-1}(B; \mathbb{Z})$ so that $\rho_{\mathbb{Z}/2} W = w_{p-1}(\pi)$ and suppose that $H^{2p-2}(B; \mathbb{Z})$ has no element of order 2. Define (using (2.7)) $P = \frac{1}{4}(p_i(\pi) - W^2)$ for $i = \frac{2p-2}{4}$. Then, there is an element $a \in H^{p-1}(E; R)$, so that*

$$H^*(E; R) \cong H^*(B; R) \otimes_R R[a] / \langle 1 \otimes a^2 - \rho_R W \otimes a - \rho_R P \otimes 1 \rangle.$$

The isomorphism is given by $x \otimes a^i \mapsto \pi^*(x) \smile a^i$.

Proof. By (2.4), every $y \in H^i(E)$ can be written as $y = \pi^*(x_1) + \pi^*(x_2) \smile a$ for unique elements $x_1 \in H^i(B)$, $x_2 \in H^{i-p+1}(B)$. In particular, there are $\alpha \in H^{2p-2}(B)$ and $\beta \in H^{p-1}(B)$ so that

$$a \smile a = \pi^*(\alpha) + \pi^*(\beta) \smile a.$$

Thus, $H^*(E)$ is isomorphic to

$$H^*(B) \otimes_R R[a] / \langle 1 \otimes a^2 - \beta \otimes a - \alpha \otimes 1 \rangle.$$

For the values of α and β , first consider the case $R = \mathbb{Z}$. Then, by [14, Theorem III], we can choose a so that $\beta = W$. Further, by [14, Theorem IV], we have

$$p_i(\pi) = 4\alpha + \beta^2.$$

Since $H^{2p-2}(B)$ has no element of order 2, this equation determines α uniquely, and we can write

$$\alpha = \frac{1}{4}(p_i(\pi) - \beta^2) = \frac{1}{4}(p_i(\pi) - W^2) = P.$$

For an arbitrary commutative ring R , first note that $\psi \circ \rho_R = \rho_R \circ \psi$. This follows by (2.2) and from the fact that the Thom classes $u_{\mathbb{Z}}$ and u_R with coefficients in \mathbb{Z} and R , respectively, satisfy $\rho_R u_{\mathbb{Z}} = u_R$, cf. [15, Remark on p. 111].

Thus, for any $a \in H^{p-1}(E)$ with $\psi(a) = 1$, we have $\psi(\rho_R a) = \rho_R \psi(a) = 1$ and we denote $\rho_R a \in H^{p-1}(E; R)$ again by a . Hence, $\alpha = \rho_R P$ and $\beta = \rho_R W$. □

Recall that a *stable characteristic class* is a sequence of elements $c \in H^i(\text{BO}(p); R)$ for all $p \in \mathbb{N}_0$ (and we denote all these elements by c) satisfying $(Bj_p)^* c = c$ for all p , where $Bj_p : \text{BO}(p) \rightarrow \text{BO}(p+1)$ denotes the map obtained from the inclusion $\text{O}(p) \hookrightarrow \text{O}(p+1)$. For a vector bundle $\xi : E \rightarrow B$ of rank p with classifying map $f : B \rightarrow \text{BO}(p)$, the class $c(\xi) \in H^i(B; R)$ is then defined by $c(\xi) = f^* c$. The property $(Bj_p)^* c = c$ implies $c(\xi \oplus \underline{\mathbb{R}}_B) = c(\xi)$ for any vector bundle $\xi : E \rightarrow B$, where $\underline{\mathbb{R}}_B$ denotes the trivial line bundle over B . If one considers vector bundles with an additional structure, such as an orientation or a spin structure, the orthogonal group $\text{O}(p)$ is replaced by the corresponding structure group, such as $\text{SO}(p)$ or $\text{Spin}(p)$. Examples of stable characteristic classes are the Pontryagin classes p_i (with $R = \mathbb{Z}$) and the Stiefel-Whitney classes w_i (with $R = \mathbb{Z}/2$).

The following is well known. We include the proof for convenience.

Proposition 2.5. *Let $E \xrightarrow{\pi} B$ be a linear sphere bundle and let $c \in H^i(\text{BO}(p); R)$ be a stable characteristic class. Denote the vector bundle corresponding to π by ξ . Then,*

$$c(TE) = \pi^* c(TB \oplus \xi).$$

Proof. Let $\iota : E \hookrightarrow \bar{E}$ be the inclusion. Then, $\iota^* T\bar{E} \cong TE \oplus \underline{\mathbb{R}}_E$, the trivial factor corresponds to the normal bundle of $E = \partial \bar{E}$. Further, $T\bar{E} \cong \pi^* TB \oplus \pi^* \xi$, which can be verified by turning the bundle into a Riemannian submersion, since then the horizontal distribution is isomorphic to $\pi^* TB$ and the vertical distribution is isomorphic to $\pi^* \xi$.

It follows that

$$c(E) = c(TE \oplus \underline{\mathbb{R}}_E) = c(\iota^* T\bar{E}) = \iota^* c(\pi^*(TB \oplus \xi)) = \pi^* c(TB \oplus \xi) = \pi^* c(TB \oplus \xi). \quad \square$$

For $q = 4k$, $p = 2k + 1$, Propositions 2.4 and 2.5 yield the following corollary.

Corollary 2.6. *Let $E \xrightarrow{\pi} B^{4k}$ be an oriented linear S^{2k} -bundle with $e(\pi) = 0$, where B is closed, connected, and oriented. Then, for any $W \in H^{2k}(B; \mathbb{Z})$ with $\rho_{\mathbb{Z}/2} W = w_{2k}(\pi)$, there exists $a \in H^{2k}(E; \mathbb{Z})$ so that*

$$H^{2k}(E; \mathbb{Z}) = \pi^*(H^{2k}(B; \mathbb{Z})) \oplus \mathbb{Z}a$$

and for $x_1, x_2, x_3 \in H^{2k}(B; \mathbb{Z})$, we have

$$\begin{aligned} \mu_E(\pi^* x_1, \pi^* x_2, \pi^* x_3) &= 0, \\ \mu_E(\pi^* x_1, \pi^* x_2, a) &= \langle x_1 \smile x_2, [B] \rangle, \\ \mu_E(\pi^* x_1, a, a) &= \langle x_1 \smile W, [B] \rangle, \\ \mu_E(a, a, a) &= \frac{1}{4} \langle 3W^2 + p_k(\pi), [B] \rangle. \end{aligned}$$

Further, for $x \in H^{2k}(B; \mathbb{Z})$, we have

$$2p_k(E)(\pi^*x) = 0,$$

$$p_k(E)(a) = \langle p_k(TB \oplus \xi), [B] \rangle.$$

For the proof of Theorem B, we will need the following lemma to show that certain spaces cannot be the total space of a linear sphere bundle.

Lemma 2.7. *Let $E \xrightarrow{\pi} B^q$ be a linear S^{p-1} -bundle with B closed, oriented, and connected.*

- (1) *For the Euler characteristic, we have $\chi(E) = \chi(B)\chi(S^{p-1})$. In particular, $\chi(E)$ vanishes if p is even and $\chi(E)$ is even if p is odd.*
- (2) *If all cohomology groups of E in odd degrees vanish, then $b_j(E)$ is even for $j = \frac{p+q-1}{2}$.*
- (3) *If $p + q - 1 = 6k$ and $p_k(E) \neq 0$ and*
 - $2k + 1 \leq p \leq 6k$, or
 - $1 < p \leq 2k$ and E is $(2k - 1)$ -connected,*then μ_E is trivial on $\ker(p_k(E)) \times \ker(p_k(E)) \times \ker(p_k(E))$.*

Proof. The first claim is well known and holds more generally for arbitrary fiber bundles, see [23]. For the second claim, first note that, since E only has cohomology in even degrees, its Euler characteristic is positive. Hence, by item (1), we have that p is odd, so $\chi(E)$ is even. Then, it follows by Poincaré duality, that

$$\chi(E) = 2 \sum_{i=0}^{j-1} b_i(E) + b_j(E),$$

and hence $b_j(E)$ is even.

Now suppose that $p + q - 1 = 6k$ and $p_k(E) \neq 0$. We will consider coefficients in \mathbb{Z} . If $p \geq 2k + 1$, that is, $q \leq 4k$, it follows from Proposition 2.5 that $p_k(E) \in H^{4k}(E)$ can only be nontrivial if $p = 2k + 1$, since otherwise $H^{4k}(B)$ is trivial. Then, by Corollary 2.6, the trilinear form is trivial on $\ker(p_k(E))$ provided $e(\pi)$ vanishes. If $e(\pi)$ is nontrivial, the map $H^{2k}(B) \xrightarrow{\pi^*} H^{2k}(E)$ is an isomorphism by the Gysin sequence, so μ_E vanishes on all of $H^{2k}(E)$.

Finally, we assume that $4k < q < 6k$ and that E is $(2k - 1)$ -connected. Then, for $0 < i + p < 2k$, by the Gysin sequence, we have an isomorphism

$$H^i(B) \xrightarrow{\sim e(\pi)} H^{i+p}(B).$$

Hence, we have for $0 < i < 2k$

$$H^i(B) \cong \begin{cases} \mathbb{Z}, & p \mid i, \\ 0, & \text{else.} \end{cases}$$

Again, from the Gysin sequence, we obtain the following exact sequence.

$$H^{2k}(B) \xrightarrow{\pi^*} H^{2k}(E) \xrightarrow{\psi} H^{2k-p+1}(B).$$

We have $H^{2k-p+1}(B) \cong \mathbb{Z}$ or 0. Let $y \in H^{4k}(B)$ so that $\pi^*y = p_k(E)$ (which exists by Proposition 2.5). Then, for every $x \in H^{2k}(B)$, we have

$$\pi^*(x) \smile p_k(E) = \pi^*(x \smile y) = 0.$$

Hence, if $p_k(E) \neq 0$, we have $H^{2k-p+1}(B) \cong \mathbb{Z}$ and ψ is nontrivial, otherwise $p_k(E)$ would be trivial on $H^{2k}(E)$, which would imply $p_k(E) = 0$ by Poincaré duality. Hence, if $a \in H^{2k}(E)$ is a preimage of a generator of $\text{im } \psi$, every $y \in H^{2k}(E)$ can be written as $y = \pi^*x + \lambda a$, where $x \in H^{2k}(B)$. Since $p_k(E)$ is trivial on $\pi^*H^{2k}(B)$, it follows that $\ker(p_k(E)) = \pi^*H^{2k}(B)$, on which μ_E is trivial. \square

We now construct linear S^{2k} -bundles over a closed, oriented $4k$ -dimensional base B^{4k} . For that, recall that a collapse map $B \rightarrow S^{4k} \cong D^{4k}/\partial D^{4k}$ for an embedding $D^{4k} \hookrightarrow B$ is defined as the identity on D^{4k}° and maps all other points to ∂D^{4k} . Since any two orientation-preserving embeddings $D^{4k} \hookrightarrow B$ are isotopic [17, Theorem 5.5], any two orientation-preserving collapse maps are homotopic.

Further, we set

$$\nu_k = \begin{cases} 2, & k = 1, 4, \\ 8, & k = 2, \\ 1, & k = 3 \text{ or } k > 4. \end{cases}$$

Definition 2.8. Let B^{4k} be a closed, oriented $4k$ -dimensional manifold and let $\alpha \in \mathbb{Z}$. We define the linear S^{2k} -bundle $\pi_{\alpha,B} : E \rightarrow B$ as the bundle classified by the composition of an orientation-preserving collapse map $B \rightarrow S^{4k}$ and a preimage of $\nu_k\alpha \in \mathbb{Z} \cong \pi_{4k}(\text{BSO})$ in $\pi_{4k}(\text{BSO}(2k + 1))$.

The existence of such a preimage is guaranteed by [9, Theorem 1.1 and Proposition 2.1]. For $k = 1, 2$ this preimage is unique since $\pi_4(\text{BSO}(3)) \cong \pi_8(\text{BSO}(5)) \cong \mathbb{Z}$, and for $k > 2$, it is nonunique in general. For example, we have $\pi_{12}(\text{BSO}(7)) \cong \mathbb{Z} \oplus \mathbb{Z}/2$ and $\pi_{16}(\text{BSO}(9)) \cong \mathbb{Z} \oplus (\mathbb{Z}/2)^3$ (see, e.g., [1, App. A, Table 6.VII]), showing that for $k = 3, 4$, there exist 2, resp. 8, preimages. We note that the choice of preimage is not relevant for the results of this article.

Lemma 2.9. Set $\lambda_k = \nu_k \frac{3-(-1)^k}{2} (2k - 1)!$. Then, the bundle $\pi_{\alpha,B}$ satisfies the following:

$$\begin{aligned} w_i(\pi_{\alpha,B}) &= \begin{cases} 1, & i = 0, \\ 0, & \text{else,} \end{cases} \\ p_i(\pi_{\alpha,B}) &= \begin{cases} 1, & i = 0, \\ \alpha\lambda_k[B]^*, & i = k, \\ 0, & \text{else,} \end{cases} \\ e(\pi_{\alpha,B}) &= 0. \end{aligned}$$

Proof. We first consider the bundle $\pi_{\alpha,S^{4k}}$ over S^{4k} . By [2, Theorem 26.5], the k 0th Pontryagin class p_k of a stable vector bundle corresponding to a generator of the group $\pi_{4k}(\text{BSO}) \cong \mathbb{Z}$ is given by $\frac{3-(-1)^k}{2} (2k - 1)! [S^{4k}]^*$. Further, since S^{4k} has nonvanishing cohomology groups only in degrees 0

and $4k$ and since $\pi_{\alpha, S^{4k}}$ has rank $(2k + 1) < 4k$, all of the characteristic classes $w_i(\pi_{\alpha, S^{4k}})$ ($i \neq 0$), $p_i(\pi_{\alpha, S^{4k}})$ ($i \neq 0, k$) and $e(\pi_{\alpha, S^{4k}})$ vanish.

For arbitrary base B^{4k} , the bundle $\pi_{\alpha, B}$ is the pull-back of $\pi_{\alpha, S^{4k}}$ along an orientation-preserving collapse map $h : B \rightarrow S^{4k}$, since an orientation-preserving collapse map of S^{4k} is homotopic to the identity. The claim now follows from the naturality properties of w_i , p_i , and e and the fact that h has degree 1, so $h^*[S^{4k}]^* = [B]^*$. □

Remark 2.10. Note that for $k \geq 3$, we have

$$\binom{2k + 1}{k} = \frac{(2k + 1)!}{k!(k + 1)!} = (2k - 1)! \frac{2k(2k + 1)}{k!(k + 1)!}$$

and

$$\frac{2k(2k + 1)}{k!(k + 1)!} \leq \frac{2k(2k + 2)}{k!(k + 1)!} = \frac{4}{(k - 1)!k!} < 1,$$

showing that $\binom{2k+1}{k} < (2k - 1)! \leq \lambda_k$. Since $\lambda_1 = 4$ and $\lambda_2 = 48$, the inequality $\binom{2k+1}{k} < \lambda_k$ holds for all $k \in \mathbb{N}$. This fact will be useful in the proof of Theorem B.

Remark 2.11. When $k = 1$ and $B = S^4$, the linear S^2 -bundles over B constructed in Lemma 2.9 cover, in fact, all possible linear S^2 -bundles over S^4 , see, for example, [20, Corollary 5.2]. If $B = \pm \mathbb{C}P^2$, then, by [20, Corollary 5.2], isomorphism classes of linear S^2 -bundles over B are in bijection with $\mathbb{Z} \times \{0, 1\}$, where the bijection assigns to (α, β) the linear S^2 -bundle π with $p_1(\pi) = (4\alpha \pm \beta)[B]^*$ and $w_2(\pi) = \beta b$, where $b \in H^2(\mathbb{C}P^2; \mathbb{Z}/2)$ denotes a generator. Hence, the bundles constructed in Lemma 2.9 are precisely those corresponding to $(\alpha, 0) \in \mathbb{Z} \times \{0, 1\}$.

We will now restrict to the following base manifolds.

Definition 2.12. Let $k, m \in \mathbb{N}$ and for $\bar{\gamma} = (\gamma_1, \dots, \gamma_m) \in \{\pm 1\}^m$, we define the manifold $B_{\bar{\gamma}}^{4k}$ by

$$B_{\bar{\gamma}}^{4k} = \gamma_1 \mathbb{C}P^{2k} \# \dots \# \gamma_m \mathbb{C}P^{2k}.$$

Let $B = B_{\bar{\gamma}}^{4k}$ and let $b_i \in H^2(\gamma_i \mathbb{C}P^{2k})$ be a generator of $H^*(\gamma_i \mathbb{C}P^{2k})$ so that $\gamma_i b_i^k = [\gamma_i \mathbb{C}P^{2k}]^*$. Then, we have a ring isomorphism

$$H^*(B) \cong \mathbb{Z}[b_1, \dots, b_m] / \langle b_i b_j, \gamma_i b_i^{2k} - \gamma_j b_j^{2k}, b_i^{2k+1} \mid i \neq j \rangle$$

given by mapping each $b_i \in H^2(\gamma_i \mathbb{C}P^{2k})$ (considered as an element of $H^2(B)$ via the collapse $B \rightarrow \gamma_i \mathbb{C}P^{2k}$) to the generator b_i on the right-hand side. This also determines $H^*(B; R)$ via $H^*(B; R) \cong H^*(B) \otimes R$ (as $\mathbb{C}P^{2k}$, and thus B , has a cell decomposition with only cells in even dimensions).

If $E \xrightarrow{\pi} B$ is a linear sphere bundle, we will denote the images $\pi^* b_i$ in $H^*(E)$ again by b_i .

Further,

$$w_j(B) = \begin{cases} \binom{2k+1}{j/2 \sum_i \rho_{\mathbb{Z}/2} b_i^{j/2}}, & j \text{ even,} \\ 0, & \text{else,} \end{cases}$$

and

$$p_j(B) = \binom{2k+1}{j} \sum_i b_i^{2j},$$

see [15, Corollary 11.15 and Example 15.6].

The following corollary is now an immediate consequence of Propositions 2.4 and 2.5 and Lemma 2.9. To simplify notation, we will again write b_i for $\rho_R b_i$.

Corollary 2.13. *Let $E \xrightarrow{\pi} B_{\frac{A}{\gamma}}^{4k}$ be an oriented linear S^{2k} -bundle corresponding to $\alpha \in \mathbb{Z}$ in Lemma 2.9. Then,*

$$H^*(E; R) \cong R[a, b_1, \dots, b_m] / \left\langle b_i b_j, \gamma_i b_i^{2k} - \gamma_j b_j^{2k}, b_i^{2k+1}, a^2 - \frac{1}{4} \alpha \lambda_k \gamma_1 b_1^{2k} \mid i \neq j \right\rangle,$$

where a has degree $2k$ and b_1, \dots, b_m have degree 2. Further,

$$w_j(E) = \begin{cases} \binom{2k+1}{j/2 \sum_i b_i^{j/2}}, & j \text{ even,} \\ 0, & \text{else,} \end{cases}$$

$$p_j(E) = \begin{cases} \left(\binom{2k+1}{k} \sum_i \gamma_i + \alpha \lambda_k \right) \gamma_1 b_1^{2k}, & j = k, \\ \binom{2k+1}{j} \sum_i b_i^{2j}, & \text{else.} \end{cases}$$

In particular, we have

$$H^{2k}(E; \mathbb{Z}) = \bigoplus_i \mathbb{Z} b_i^k \oplus \mathbb{Z} a$$

and

$$\mu_E(b_i^k \smile b_j^k \smile b_m^k) = 0,$$

$$\mu_E(b_i^k \smile b_j^k \smile a) = \delta_{ij} \gamma_i,$$

$$\mu_E(b_i^k \smile a \smile a) = 0,$$

$$\mu_E(a \smile a \smile a) = \frac{\lambda_k}{4} \alpha,$$

$$\begin{aligned} \omega_2(E)^k &= \sum_i b_i^k, \\ p_k(E)(b_i) &= 0, \\ p_k(E)(a) &= \binom{2k+1}{k} \sum_i \gamma_i + \lambda_k \alpha. \end{aligned}$$

3 | PLUMBINGS ACCORDING TO A BIPARTITE GRAPH

Let G be a labeled bipartite graph, that is, $G = (U, V, E, \pi, \delta)$, where U and V are the sets of vertices, which are assumed to be finite, $E \subseteq U \times V$ is the set of edges, $\delta : E \rightarrow \{\pm 1\}$ is a function, and π assigns to each vertex an oriented linear disc bundle in the following way: For fixed $p, q \in \mathbb{N}$, we assign to each $u \in U$ an oriented linear disc bundle $D^p \hookrightarrow \bar{E}_u \xrightarrow{\pi_u} B_u^q$ and to each $v \in V$ an oriented linear disc bundle $D^q \hookrightarrow \bar{E}_v \xrightarrow{\pi_v} B_v^p$. We assume that all base spaces are connected and oriented. We call such a graph G a *geometric plumbing graph*. We refer to [20, Section 2.1] and the references therein for an introduction to plumbing and we use the notation established there.

Definition 3.1. For a geometric plumbing graph G , we define \bar{M}_G as the boundary connected sum of the manifolds obtained by plumbing the bundles π_u and π_v according to each connected component of the graph G , where each edge e corresponds to plumbing with sign $\delta(e)$. We set $M_G = \partial \bar{M}_G$.

We equip each total space \bar{E}_u and \bar{E}_v with the orientation induced from the base manifolds and the fiber orientations (cf. Subsection 2.2). Then, recall from [20, Section 2.1] that \bar{M}_G can be oriented so that the orientation agrees with that of \bar{E}_u and \bar{E}_v if p or q is even and with that of $-\bar{E}_u$ and \bar{E}_v if p and q are odd. Further, recall from Subsection 2.2 that the induced orientation of E_u (E_v) as a boundary coincides with the induced orientation from the bundle structure if and only if q is even (p is even). Thus, the induced orientation on M_G as a boundary coincides with the orientations of E_u and E_v induced from the bundle structures if and only if p and q are even, and if one of p and q is odd, then M_G can be oriented so that the orientation agrees with the orientations of $-E_u$ and E_v . We will always choose these orientations in the following.

3.1 | Modifications of graphs

Let G be a geometric plumbing graph. Our goal in this section is to simplify the graph data as much as possible without changing the diffeomorphism type of M_G .

Proposition 3.2 (Sign of a separating edge). *Suppose that G is of the form*

$$G_1 \xrightarrow{e} G_2$$

with subgraphs G_1 and G_2 of G . Let G' be the graph obtained from G by reversing the sign of e and by reversing all base and fiber orientations of the bundles associated to vertices in G_2 . Then, M_G is diffeomorphic to $M_{G'}$.

Proposition 3.3 (Vertex of Degree 1). *Suppose that G is of the form*

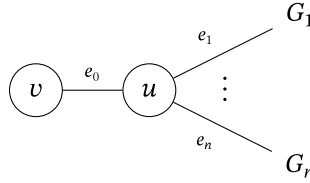

with subgraphs G_1, \dots, G_n of G . Let G_0 be the graph

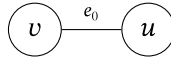

with corresponding restrictions of δ and π . If π_v is trivial with $B_v = S^p$, then M_G is diffeomorphic to $M_{G_0} \# M_{G_1} \# \dots \# M_{G_n}$, that is, we can replace G by the disjoint union of the subgraphs G_0, \dots, G_n .

Proposition 3.4. *Let G be the graph*

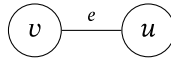

where π_v is trivial with $B_v = S^p$ and $B_u = S^q$. Then, $M_G \cong S^{p+q-1}$.

Proposition 3.5 (Vertex of degree 2). *Suppose that G is of the following form:*

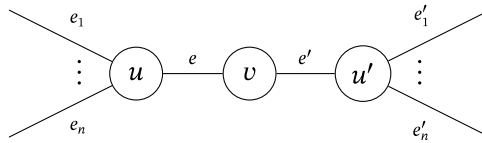

Suppose that π_v is trivial with $B_v = S^p$ and $\delta(e) = 1, \delta(e') = -1$. Define $\pi_{\hat{u}}$ as the fiber-connected sum of π_u and $\pi_{u'}$. Then we can replace G by the following graph without changing the diffeomorphism type of M_G .

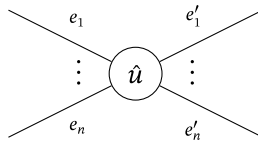

Remark 3.6.

- (1) Proposition 3.3 generalizes [7, Proposition 2.6] and [21, Satz 5.9 (A)].
- (2) By Proposition 3.2, we can, after possibly reversing base and fiber orientations in the corresponding subgraphs, apply Proposition 3.5 without any condition on the signs of e and e' .

Proposition 3.2 directly follows from the fact that, by reversing the orientations as assumed, the gluing maps for the plumbings do not change. Proposition 3.5 follows from [7, Lemma 2.10]. For convenience, we give the proof below.

Proof of Proposition 3.5, cf. [7, Lemma 2.10]. Denote the graph

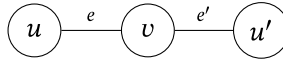

by G' . Then,

$$\begin{aligned} M_{G'} &\cong \pi_u^{-1}(B_u \setminus D^{q^\circ}) \cup_{S^{q-1} \times S^{p-1}} (S^p \setminus (D^p \sqcup D^p)^\circ) \times S^{q-1} \cup_{S^{q-1} \times S^{p-1}} \pi_{u'}^{-1}(B_{u'} \setminus D^{q^\circ}) \\ &\cong \pi_u^{-1}(B_u \setminus D^{q^\circ}) \cup_{S^{q-1} \times S^{p-1}} (S^{p-1} \times I) \times S^{q-1} \cup_{S^{q-1} \times S^{p-1}} \pi_{u'}^{-1}(B_{u'} \setminus D^{q^\circ}) \\ &\cong \pi_u^{-1}(B_u \setminus D^{q^\circ}) \cup_{S^{q-1} \times S^{p-1}} \pi_{u'}^{-1}(B_{u'} \setminus D^{q^\circ}). \end{aligned}$$

Here, we identify the boundaries of $\pi_u^{-1}(B_u \setminus D^{q^\circ})$ and $\pi_{u'}^{-1}(B_{u'} \setminus D^{q^\circ})$ with $S^{q-1} \times S^{p-1}$ via local trivializations $D^q \times S^{p-1} \hookrightarrow E_u, E_{u'}$ and consider gluings to different connected components of the boundaries of $(S^p \setminus (D^p \sqcup D^p)^\circ) \times S^{q-1}$ and $(S^{p-1} \times I) \times S^{q-1}$ that can both be identified canonically with the disjoint union of two copies of $S^{p-1} \times S^{q-1} \cong S^{q-1} \times S^{p-1}$.

Since the induced orientations on the boundary components of $S^{p-1} \times I$ are opposite to each other, and by the assumption on the signs, the gluing map reverses the orientation on the S^{q-1} -factor and preserves the orientation on the S^{p-1} -factor. Hence, the claim follows. \square

Proof of Proposition 3.4. By possibly reversing the orientations on the base and fibers of π_u , we can assume that $\delta(e) = 1$. Let $T : S^{q-1} \rightarrow \text{SO}(p)$ be the clutching function for π_u . Then, we have

$$M_G \cong (S^{q-1} \times D^p) \cup_{\tilde{T}} (D^q \times S^{p-1}),$$

where $\tilde{T} : S^{q-1} \times S^{p-1} \rightarrow S^{q-1} \times S^{p-1}$ is defined by

$$\tilde{T}(x, y) = (x, T_x(y)).$$

We extend this map to $S^{q-1} \times D^p$, that is, we define the diffeomorphism $\bar{T} : S^{q-1} \times D^p \rightarrow S^{q-1} \times D^p$ by $\bar{T}(x, y) = (x, T_x(y))$, so by definition, $\bar{T}|_{S^{q-1} \times S^{p-1}} = \tilde{T}$. Hence,

$$M_G \cong \bar{T}(S^{q-1} \times D^p) \cup_{\tilde{T}} (D^q \times S^{p-1}) = (S^{q-1} \times D^p) \cup_{\text{id}} (D^q \times S^{p-1}) \cong S^{p+q-1},$$

where the last isomorphism follows by identifying $D^q \times D^p$ with D^{p+q} by smoothing corners and considering the boundaries of each space. \square

For the proof of Proposition 3.3, we need the following notion.

Definition 3.7. An embedding $\varphi : D^q \times S^{p-1} \hookrightarrow M^{p+q-1}$ into a manifold M is called *trivial*, if there is an embedding $\bar{\varphi} : D^{q-1} \times D^p \hookrightarrow M$ so that $\varphi|_{D^{q-1} \times S^{p-1}} = \bar{\varphi}|_{D^{q-1} \times S^{p-1}}$.

Here, we consider $D^{q-1} \subseteq D^q$ according to the embedding $\mathbb{R}^{q-1} \cong \mathbb{R}^{q-1} \times \{0\} \subseteq \mathbb{R}^q$.

Lemma 3.8. *Let M be connected. Then, any two trivial embeddings $\varphi_1, \varphi_2 : D^q \times S^{p-1} \hookrightarrow M$, which are orientation-preserving with respect to the same orientation of M if M is orientable, are isotopic.*

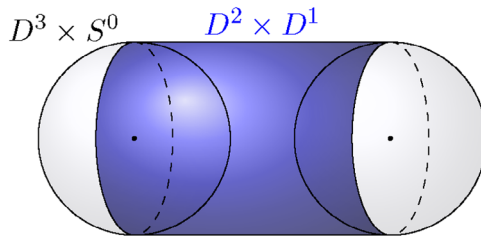

FIGURE 1 A trivial embedding of $D^3 \times S^0$.

Proof. First note that we can assume that both $\bar{\varphi}_1$ and $\bar{\varphi}_2$ are orientation preserving if M is orientable, since otherwise we can replace $\bar{\varphi}_i$ by the map

$$(x_1, \dots, x_{q-1}, y) \mapsto \bar{\varphi}_i(x_1, \dots, x_{q-2}, -x_{q-1}, y),$$

where $(x_1, \dots, x_{q-1}) \in D^{q-1}$ and $y \in D^p$, and φ_i by the map

$$(x_1, \dots, x_q, y) \mapsto \varphi_i(x_1, \dots, x_{q-2}, -x_{q-1}, -x_q, y),$$

where $(x_1, \dots, x_q) \in D^q$ and $y \in S^{p-1}$, which is clearly isotopic to φ_i .

By the disc theorem of Palais [17, Theorem 5.5], any two embeddings of D^p into M are ambient isotopic, where we require them to be orientation-preserving if M is orientable and $p = \dim(M)$. It follows that, after applying an ambient isotopy, we can assume that $\bar{\varphi}_1|_{\{0\} \times D^p} = \bar{\varphi}_2|_{\{0\} \times D^p}$.

If M is nonorientable, we can introduce a local orientation by enlarging the image of one of $\bar{\varphi}_i$ to a ball D^{p+q-1} , so that $\varphi_i, \bar{\varphi}_i$ are all contained in this ball. If one of φ_i is orientation-reversing with respect to the orientation of D^{p+q-1} , we can apply an isotopy of this ball that reverses the orientation, which exists by the disc theorem of Palais. If one of $\bar{\varphi}_i$ is orientation-reversing, we modify it as in the beginning of the proof. Hence, we can assume that $\varphi_i, \bar{\varphi}_i$ are all orientation-preserving.

By the uniqueness of tubular neighborhoods, see, for example, [12, Theorem 4.5.3], after applying an isotopy to one of $\bar{\varphi}_i$, there is a smooth map $\phi : D^p \rightarrow GL_+(q)$, so that $\bar{\varphi}_1(x, y) = \bar{\varphi}_2(\phi_y(x), y)$. Since D^p is contractible, there exists a smooth homotopy of ϕ to the constant map $\phi \equiv \text{id}_{\mathbb{R}^q}$. This yields an isotopy of $\bar{\varphi}_2$ so that we can assume $\bar{\varphi}_1 = \bar{\varphi}_2$. By the isotopy extension theorem, see, for example, [12, Theorem 8.1.3], this isotopy extends to a diffeotopy of M , in particular, we can assume that after the isotopy, the assumption $\varphi_i|_{D^{q-1} \times S^{p-1}} = \bar{\varphi}_i|_{D^{q-1} \times S^{p-1}}$ still holds.

Again, by the uniqueness of tubular neighborhoods, there is $\phi : S^{p-1} \rightarrow GL_+(q)$ so that, after applying an isotopy, $\varphi_1(x, y) = \varphi_2(\phi_y(x), y)$. This isotopy can be chosen so that the condition $\varphi_1|_{D^{q-1} \times S^{p-1}} = \varphi_2|_{D^{q-1} \times S^{p-1}}$ is preserved (cf. [12, Proof of Theorem 4.5.3]), hence ϕ_y fixes $\mathbb{R}^{q-1} \subseteq \mathbb{R}^q$ pointwise for all $y \in S^{p-1}$. The subspace of $GL_+(q)$ fixing \mathbb{R}^{q-1} pointwise can be identified with $\mathbb{R}^{q-1} \times \mathbb{R}_+$ by considering the image of the last standard basis vector $(0, \dots, 0, 1)$. Since this space is convex, there is a smooth homotopy of ϕ to the constant map $\text{id}_{\mathbb{R}^q}$ within this space, so φ_1 is isotopic to φ_2 . \square

Lemma 3.9. Let $\varphi_1 : D^q \times S^{p-1} \hookrightarrow M_1^{p+q-1}$, $\varphi_2 : D^p \times S^{q-1} \hookrightarrow M_2^{p+q-1}$ be embeddings into connected manifolds and let M be the manifold

$$M = M_1 \setminus \text{im}(\varphi_1)^\circ \cup_{S^{p-1} \times S^{q-1}} M_2 \setminus \text{im}(\varphi_2)^\circ,$$

where for the gluing, we identify the boundaries of $M_1 \setminus \text{im}(\varphi_1)^\circ$ and $M_2 \setminus \text{im}(\varphi_2)^\circ$ with $S^{p-1} \times S^{q-1}$ via φ_1 and φ_2 , respectively. Suppose that one of φ_1, φ_2 is trivial and that, after choosing an orientation, both φ_1 and φ_2 are orientation-preserving if both M_1 and M_2 are orientable. Then, M is diffeomorphic to $M_1 \# M_2$ if one of M_1 and M_2 is nonorientable and to $M_1 \# (-1)^{pq-p-q} M_2$ otherwise.

Proof. By possibly interchanging the roles of φ_1 and φ_2 , we can assume that φ_1 is trivial. We decompose

$$M_1 \cong M_1 \# S^{p+q-1} \cong M_1 \# ((-1)^q (S^{q-1} \times D^p) \cup_{\partial} (D^q \times S^{p-1})), \tag{3.1}$$

the orientation on $S^{q-1} \times D^p$ is chosen so that the induced orientations on the boundary of $S^{q-1} \times D^p$ and $D^q \times S^{p-1}$ are opposite to each other, so that after gluing both pieces together, we have a well-defined orientation.

The embedding $\varphi : D^q \times S^{p-1} \hookrightarrow (S^{q-1} \times D^p) \cup_{S^{q-1} \times S^{p-1}} (D^q \times S^{p-1})$ of the second factor is trivial: The map $\bar{\varphi}$ is given by

$$D^{q-1} \times D^p \cong (D^{q-1} \times D^p) \cup_{D^{q-1} \times S^{p-1}} (D^q_+ \times S^{p-1}) \hookrightarrow (S^{q-1} \times D^p) \cup_{S^{q-1} \times S^{p-1}} (D^q \times S^{p-1}),$$

where $D^q_+ \subseteq D^q$ denotes the upper half-ball and we embed $D^{q-1} \subseteq S^{q-1}$ as the upper half-sphere into the first factor (and note that in this way, we obtain an embedding $D^{q-1} \subseteq S^{q-1} \subseteq D^q$ that differs from the standard embedding $D^{q-1} \subseteq D^q$).

By Lemma 3.8, the embeddings φ and φ_1 are isotopic, where we consider both φ and φ_1 as embeddings into M_1 via (3.1) and assume that the discs removed in the connected sum construction of M_1 and S^{p+q-1} are disjoint from the images of φ, φ_1 and $\bar{\varphi}$. Hence,

$$M_1 \setminus \text{im}(\varphi_1)^\circ \cup_{S^{p-1} \times S^{q-1}} M_2 \setminus \text{im}(\varphi_2)^\circ \cong M_1 \# ((-1)^q S^{q-1} \times D^p) \cup_{S^{q-1} \times S^{p-1}} M_2 \setminus \text{im}(\varphi_2)^\circ.$$

The map $S^{p-1} \times S^{q-1} \rightarrow S^{q-1} \times S^{p-1}, (x, y) \mapsto (y, x)$, is orientation-preserving if and only if $(p-1)(q-1)$ is even. Hence, if M_2 is orientable, and if we equip it with the orientation $-(-1)^{(p-1)(q-1)} = (-1)^{pq-p-q}$, we have a well-defined orientation after gluing, so we obtain

$$\begin{aligned} &M_1 \setminus \text{im}(\varphi_1)^\circ \cup_{S^{p-1} \times S^{q-1}} M_2 \setminus \text{im}(\varphi_2)^\circ \\ &\cong M_1 \# ((-1)^q S^{q-1} \times D^p \cup_{S^{q-1} \times S^{p-1}} (-1)^{pq-p-q} M_2 \setminus \text{im}(\varphi_2)^\circ) \\ &\cong M_1 \# (-1)^{pq-p-q} M_2. \end{aligned} \quad \square$$

Proof of Proposition 3.3. First note that, by reversing the base and fiber orientations of the bundles associated to vertices in G_i (resp. v) and setting $\delta(e_i) = 1$ whenever $\delta(e_i) = -1$ for $i \in \{1, \dots, n\}$ (resp. $i = 0$), we obtain a new graph (which we also denote by G) that satisfies $\delta(e_0) = \delta(e_1) = \dots = \delta(e_n) = 1$ and leaves the diffeomorphism type of M_G unchanged by Proposition 3.2. Then, we have

$$\begin{aligned} M_{G_0} &\cong \pi_v^{-1}(B_v \setminus D^{p^\circ}) \cup_{S^{p-1} \times S^{q-1}} \pi_u^{-1}(B_u \setminus D^{q^\circ}) \\ &\cong D^p \times S^{q-1} \cup_{S^{p-1} \times S^{q-1}} \pi_u^{-1}(B_u \setminus D^{q^\circ}) \\ &\cong D^p \times S^{q-1} \cup_{S^{p-1} \times S^{q-1}} ([0, 1] \times S^{q-1} \times S^{p-1}) \cup_{S^{q-1} \times S^{p-1}} \pi_u^{-1}(B_u \setminus D^{q^\circ}), \end{aligned} \tag{3.2}$$

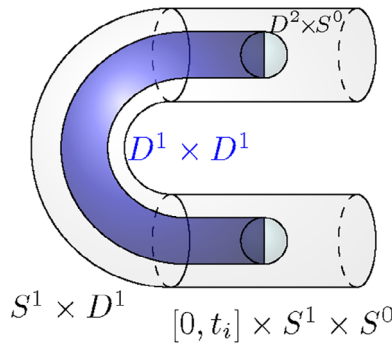

FIGURE 2 The embeddings φ_i are trivial.

where we use similar conventions for the gluing as in the proof of Proposition 3.5. Since we can view the mid-part as part of the bundle π_u , the manifold M_G is now obtained from M_{G_0} by cutting out embeddings $\varphi_i : D^q \times S^{p-1} \hookrightarrow (0, 1) \times S^{q-1} \times S^{p-1}$ of the form $t_i \times \text{id}_{S^{p-1}}$ for embeddings $t_i : D^q \hookrightarrow (0, 1) \times S^{q-1}$, and gluing in the corresponding parts of M_{G_i} . We now show that all of these embeddings are trivial.

For that, we isotope t_i so that $t_i|_{D^{q-1}} : D^{q-1} \hookrightarrow \{t_i\} \times D_i^{q-1}$ for an embedded disc $D_i^{q-1} \subseteq S^{q-1}$. We choose the discs D_i^{q-1} so that they do not intersect. Then, we define $\bar{\varphi}_i : D^{q-1} \times D^p \hookrightarrow M_{G_0}$ by identifying

$$D^{q-1} \times D^p \cong D_i^{q-1} \times D^p \cup_{D_i^{q-1} \times S^{p-1}} ([0, t_i] \times D_i^{q-1} \times S^{p-1})$$

and mapping it to

$$S^{q-1} \times D^p \cup_{S^{q-1} \times S^{p-1}} ([0, 1] \times S^{q-1} \times S^{p-1})$$

via the obvious inclusions on each part, cf. Figure 2.

Since the discs D_i^{q-1} do not intersect each other, the maps $\bar{\varphi}_i$ have pairwise disjoint image. Hence, if we equip each M_{G_i} with the orientation induced from each E_u , which equals the orientation induced from $(-1)^{pq-p-q}E_u$, it follows from Lemma 3.9 that

$$M_G \cong M_{G_0} \# M_{G_1} \# \dots \# M_{G_n}. \quad \square$$

3.2 | Fundamental group, cohomology, and characteristic classes

The goal of this section is to determine the fundamental group, the cohomology ring, and the characteristic classes of M_G . As in the previous section, we fix a geometric plumbing graph G .

Lemma 3.10. *Suppose $p, q > 2$ and that every connected component of G and every B_u and B_v are simply-connected. Then, M_G is simply-connected.*

Proof. If G_1, \dots, G_n denote the connected components of G , then $M_G \cong M_{G_1} \# \dots \# M_{G_n}$ and hence

$$\pi_1(M_G) \cong \pi_1(M_1) * \dots * \pi_1(M_n).$$

Thus, we can restrict to the case where G is connected.

The manifold M_G is obtained by gluing the spaces $\pi_u^{-1}(B_u \setminus (\bigsqcup_{\deg(u)} D^q)^\circ)$ and $\pi_v^{-1}(B_v \setminus (\bigsqcup_{\deg(v)} D^p)^\circ)$ according to G . These spaces are fiber bundles with base spaces B_u or B_v with a finite number of discs removed. Since, $p, q > 2$, it follows from the long exact sequence for fiber bundles that all these spaces are simply-connected.

The graph is simply-connected, hence, after choosing a root, it is a tree. If M_k is the manifold obtained by gluing according the subgraph of G consisting of all vertices of distance at most k from the root, then it follows inductively from van Kampen’s theorem, that M_k is simply-connected. For k large enough, we have $M_k = M_G$, and hence M_G is simply-connected. \square

Remark 3.11. If one does not require that G is simply-connected in Lemma 3.10, then, if G is connected, one can show, by using the groupoid version of van Kampen’s theorem, that $\pi_1(M_G) \cong \pi_1(G)$.

For the cohomology, we fix a commutative unital ring R . For $u \in U$ recall from (2.4) that if $e_R(\pi_u) = 0$, then we have

$$H^i(E_u) = \pi_u^*(H^i(B_u)) \oplus \theta_{a_u}(H^{i-p+1}(B_u))$$

for an element $a_u \in H^{p-1}(E_u)$ with $\psi(a_u) = 1$. We make the following assumption:

G is simply-connected and either no vertex $v \in V$ is a leaf, or G is of the form $\textcircled{v} \xrightarrow{e} \textcircled{u}$. (3.3)

Theorem 3.12. *Let G be a geometric plumbing graph with $p > 1$ satisfying (3.3), so that $e_R(\pi_u) = 0$ and B_u is closed for all $u \in U$, and each bundle π_v is trivial with $B_v \cong S^p$. Then, the cohomology ring $H^*(M_G)$ is a quotient of a subring of $\bigoplus_{u \in U} H^*(E_u)$ as follows:*

$$H^i(M_G) \cong \begin{cases} \left(\sum_{u \in U} 1_{H^0(E_u)} \right) R \cong R, & i = 0; \\ \bigoplus_{u \in U} \pi_u^* H^{p-1}(B_u) \\ \oplus \left\{ \sum_{u \in U} \lambda_u \cdot a_u \mid \lambda_u \in R \forall u \in U, \sum_{(u,v) \in E} \delta(e) \lambda_u = 0 \forall v \in V \right\}, & i = p - 1; \\ \bigoplus_{u \in U} H^q(E_u) / \bigoplus_{v \in V} \left(\sum_{e=(u,v) \in E} \delta(e) \pi_u^*[B_u]^* \right) R, & i = q; \\ \bigoplus_{u \in U} H^{p+q-1}(E_u) / \left\{ \sum_{u \in U} \lambda_u [E_u]^* \mid \sum_{u \in U} \lambda_u = 0 \right\} \cong R, & i = p + q - 1; \\ \bigoplus_{u \in U} H^i(E_u), & \text{else,} \end{cases}$$

if $q \neq p - 1$, and

$$H^i(M_G) \cong \begin{cases} \left(\sum_{u \in U} 1_{H^0(E_u)} \right) R \cong R, & i = 0; \\ \bigoplus_{u \in U} \pi_u^* H^{p-1}(B_u) / \bigoplus_{v \in V} \left(\sum_{e=(u,v) \in E} \delta(e) \pi_u^* [B_u]^* \right) R \\ \oplus \left\{ \sum_{u \in U} \lambda_u \cdot \alpha_u \mid \lambda_u \in R \ \forall u \in U, \sum_{(u,v) \in E} \delta(e) \lambda_u = 0 \ \forall v \in V \right\}, & i = q; \\ \bigoplus_{u \in U} H^{p+q-1}(E_u) / \left\{ \sum_{u \in U} \lambda_u [E_u]^* \mid \sum_{u \in U} \lambda_u = 0 \right\} \cong R, & i = 2q; \\ \bigoplus_{u \in U} H^i(E_u), & \text{else,} \end{cases}$$

if $q = p - 1$. The cup product structure is induced from $\bigoplus_{u \in U} H^*(E_u)$.

Remark 3.13. If, in the situation of Theorem 3.12, we merely require that G has simply-connected connected components instead of (3.3), we can apply Proposition 3.3 to split it into a disjoint union of subgraphs that all either satisfy (3.3), or consist of a single vertex in V . Thus, we can compute the cohomology ring of M_G by applying Theorem 3.12 to the corresponding components of G (provided that the assumptions on the bundles as in Theorem 3.12 are satisfied).

Theorem 3.14. Let c be a stable characteristic class. Let G be a geometric plumbing graph satisfying the assumptions of Theorem 3.12. If ξ_u denotes the vector bundle corresponding to the bundle π_u , then

$$c(TM_G) = \sum_{u \in U} \pi_u^* c(\xi_u \oplus TB_u),$$

where we identified $H^*(M_G)$ with a quotient of a subring of $\bigoplus_{u \in U} H^*(E_u)$ according to Theorem 3.12.

Applying Theorems 3.12 and 3.14 in dimension $6k$ yields the following corollary.

Corollary 3.15. In the setting of Theorem 3.12, let $p = 2k + 1$, $q = 4k$, that is, M_G has dimension $6k$. Let every B_u be simply-connected with torsion-free homology. Then, the following assertions hold:

- (1) If G is the graph $(\bigcirc \overset{e}{-} \bigcirc)$, then M_G is a simply-connected $6k$ -dimensional manifold with torsion-free homology and invariants

$$(H^{2k}(M_G; \mathbb{Z}), \mu_{M_G}, w_2(M_G)^k, p_k(M_G)) = (H^{2k}(B_u; \mathbb{Z}), 0, (w_2(B_u) + w_2(\pi_u))^k, 0).$$

If $k = 1$, then $b_3(M_G) = 0$.

- (2) If G has no vertex in V that is a leaf, then M_G is a simply-connected $6k$ -dimensional manifold with torsion-free homology. Further, define $A = \bigoplus_{u \in U} H^{2k}(E_u; \mathbb{Z})$, $\mu = \sum_{u \in U} \mu_{E_u}$ and

$p = \sum_{u \in U} p_k(E_u)$ (viewed as a linear form on A). Then, $H^{2k}(M_G; \mathbb{Z})$ is given by

$$\bigoplus_{u \in U} \pi_u^* H^{2k}(B_u; \mathbb{Z}) \oplus \left\{ \sum_{u \in U} \lambda_u \cdot a_u \mid \lambda_u \in \mathbb{Z} \forall u \in U, \sum_{e=(u,v) \in E} \delta(e) \lambda_u = 0 \forall v \in V \right\} \subseteq A,$$

and we have $w_2(M_G)^k = \sum_{u \in U} \pi_u^*(w_2(B_u) + w_2(\pi_u))^k$ and μ_{M_G} and $p_k(M_G)$ are the restrictions of μ and p to $H^{2k}(M_G; \mathbb{Z})$, respectively. If $k = 1$, then $b_3(M_G) = 0$.

The rest of this section consists of the proofs of Theorems 3.12 and 3.14.

Lemma 3.16. Let $S_k^n = S^n \setminus (\bigsqcup_k D^n)^\circ$ with $n \geq 2$. Then, the inclusion $\iota : \bigsqcup_k S^{n-1} \hookrightarrow S_k^n$ of the boundary induces an injective map

$$\iota^* : H^{n-1}(S_k^n) \rightarrow H^{n-1}(\bigsqcup_k S^{n-1}) \cong \bigoplus_k H^{n-1}(S^{n-1})$$

with image generated by the elements $a_j - a_i$, where a_i is a positively oriented generator of the i th copy of $H^{n-1}(S^{n-1})$ with respect to the orientation induced by S_k^n .

Proof. We use Lefschetz duality to obtain the following commutative diagram with exact rows and where the vertical arrows are isomorphisms:

$$\begin{array}{ccccccccc} H^{n-1}(S_k^n, \bigsqcup_k S^{n-1}) & \longrightarrow & H^{n-1}(S_k^n) & \xrightarrow{\iota^*} & H^{n-1}(\bigsqcup_k S^{n-1}) & \longrightarrow & H^n(S_k^n, \bigsqcup_k S^n) & \longrightarrow & 0 \\ \downarrow \cong & & \downarrow \cong & & \downarrow \cong & & \downarrow \cong & & \\ H_1(S_k^n) & \longrightarrow & H_1(S_k^n, \bigsqcup_k S^{n-1}) & \longrightarrow & H_0(\bigsqcup_k S^{n-1}) & \longrightarrow & H_0(S_k^n) & \longrightarrow & 0 \end{array}$$

If $n \geq 3$, then S_k^n is simply-connected. If $n = 2$, then the map $H_1(S_k^2) \rightarrow H_1(S_k^2, \bigsqcup_k S^1)$ is trivial as any closed loop in S_k^2 is homologous to the sum of loops in $\bigsqcup_k S^1$ it encloses. Hence, the map ι^* is injective. To compute the image, it suffices to determine the kernel of the map $H_0(\bigsqcup_k S^{n-1}) \rightarrow H_0(S_k^n)$. The claim now follows from the fact that we can join any two boundary components by a path and that the vertical map $H^{n-1}(\bigsqcup_k S^{n-1}) \rightarrow H_0(\bigsqcup_k S^{n-1})$ is given by Poincaré duality. \square

For each $e = (u, v) \in E$, we denote the embeddings along which the spaces \bar{E}_u and \bar{E}_v get glued by $\varphi_{(u,v)} : D^q \times D^p \hookrightarrow \bar{E}_u$ and $\varphi_{(v,u)} : D^p \times D^q \hookrightarrow \bar{E}_v$, respectively, and by $I_{p,q}^\pm : D^p \times D^q \rightarrow D^q \times D^p$ the diffeomorphism

$$I_{p,q}^\pm(x_1, \dots, x_p, y_1, \dots, y_q) = (\pm y_1, y_2, \dots, y_q, \pm x_1, x_2, \dots, x_p),$$

so that \bar{M}_G is the result of the following pushout:

$$\begin{array}{ccc} \bigsqcup_{e \in E} D^q \times D^p & \xleftarrow{\bigsqcup_{e=(u,v) \in E} \varphi_{(v,u)} \circ I_{q,p}^{\delta(e)}} & \bigsqcup_{v \in V} \bar{E}_v \\ \downarrow \bigsqcup_{(u,v) \in E} \varphi_{(u,v)} & & \downarrow \\ \bigsqcup_{u \in U} \bar{E}_u & \xleftarrow{\hspace{10em}} & \bar{M}_G \end{array}$$

17538424, 2024, 4, Downloaded from https://onlinelibrary.wiley.com/doi/10.1112/topol.70007 by Philipp Kaiser - Test, Wiley Online Library on [12/11/2024]. See the Terms and Conditions (https://onlinelibrary.wiley.com/terms-and-conditions) on Wiley Online Library for rules of use; OA articles are governed by the applicable Creative Commons License

Now let

$$X = \overline{M}_G \setminus \bigcup_{u \in U} \text{Int}(\overline{E}_u) = \bigcup_{v \in V} \overline{E}_v \setminus \left(\bigcup_{(u,v) \in E} \varphi_{(v,u)}(D^{p^\circ} \times D^q) \right) \cup \bigcup_{u \in U} E_u,$$

where we considered the spaces \overline{E}_v and \overline{E}_u as subspaces of \overline{M}_G . Alternatively, the space X is the result of the following pushout:

$$\begin{array}{ccc}
 \bigsqcup_{e \in E} D^q \times S^{p-1} & \xleftarrow{\bigsqcup_{e=(u,v) \in E} \varphi_{(v,u)} \circ I_{q,p}^{\delta(e)}} & \bigsqcup_{v \in V} \overline{E}_v \setminus \left(\bigcup_{(u,v) \in E} \varphi_{(v,u)}(D^{p^\circ} \times D^q) \right) \\
 \downarrow \bigsqcup_{(u,v) \in E} \varphi_{(u,v)} & & \downarrow \\
 \bigsqcup_{u \in U} E_u & \xleftarrow{\hspace{10em}} & X
 \end{array} \tag{3.4}$$

For every $v \in V$, by assumption, the manifold $\overline{E}_v \setminus (\bigcup_{(u,v) \in E} \varphi_{(v,u)}(D^{p^\circ} \times D^q))$ can be identified with $S^p_{\text{deg}(v)} \times D^q$.

Lemma 3.17. *Suppose that G satisfies (3.3). Then, the inclusion $\bigsqcup_{u \in U} E_u \hookrightarrow X$ induces an injective map $H^i(X) \rightarrow \bigoplus_{u \in U} H^i(E_u)$ for every i with image given by*

- $\left(\sum_{u \in U} 1_{H^0(E_u)} \right) R \cong R$, if $i = 0$;
- $\bigoplus_{u \in U} \pi_u^* H^{p-1}(B_u) \oplus \left\{ \sum_{u \in U} \lambda_u \cdot a_u \mid \lambda_u \in R \forall u \in U, \sum_{(u,v) \in E} \delta(e) \lambda_u = 0 \forall v \in V \right\}$, if $i = p - 1$;
- $\bigoplus_{u \in U} H^i(E_u)$, else.

We will henceforth identify the cohomology of X with its image in $\bigoplus_{u \in U} H^*(E_u)$.

Proof. The Mayer–Vietoris sequence for the pushout (3.4) is given as follows:

$$\dots \longrightarrow H^i(X) \longrightarrow \bigoplus_{v \in V} H^i(S^p_{\text{deg}(v)}) \bigoplus_{u \in U} H^i(E_u) \longrightarrow \bigoplus_{e \in E} H^i(S^{p-1}) \longrightarrow H^{i+1}(X) \longrightarrow \dots$$

To simplify notation, we will write u, v , or e for a canonical generator of a group $H^i(M^n)$ (e.g., $[M]^*$ if $i = n$ or 1 if $i = 0$), where M is related to $u \in U, v \in V$ or $e \in E$ (e.g., as the fiber, base, or total space of π_u or π_v).

For $i = 0$, the middle map of the sequence is given by

$$\bigoplus_{v \in V} Rv \bigoplus_{u \in U} Ru \longrightarrow \bigoplus_{e \in E} Re, \quad v \mapsto \sum_{e=(u,v) \in E} e, \quad u \mapsto - \sum_{e=(u,v) \in E} e.$$

This is the linear map associated to the incidence matrix $Q(G)$, when we view G as a directed graph with edges originating from vertices in V and ending in vertices in U . Since G is simply-

connected, it follows from Lemmas A.1 and A.2 that this map is surjective with kernel generated by $\sum_{u \in U} u + \sum_{v \in V} v$. In particular, the image of $H^0(X)$ in $\bigoplus_{u \in U} H^0(E_u)$ is generated by

$$\sum_{u \in U} u = \sum_{u \in U} 1_{H^0(E_u)}.$$

For $1 \leq i < p - 1$ or $i \geq p$, the groups $H^i(S_k^p)$ and $H^i(S^{p-1})$ vanish. By exactness, the map $H^i(X) \rightarrow \bigoplus_{u \in U} H^i(E_u)$ is an isomorphism for $1 \leq i < p - 1$ and for $i > p$ (for $i = 1$, this follows from the surjectivity of the map in degree 0).

Finally, we have to investigate the following part of the sequence:

$$\begin{aligned} 0 \longrightarrow H^{p-1}(X) \longrightarrow \bigoplus_{v \in V} H^{p-1}(S_{\deg(v)}^p) \bigoplus_{u \in U} H^{p-1}(E_u) \longrightarrow \bigoplus_{e \in E} H^{p-1}(S^{p-1}) \\ \longrightarrow H^p(X) \longrightarrow \bigoplus_{u \in U} H^p(E_u) \longrightarrow 0. \end{aligned}$$

By (2.4) and by writing $e = [S^{p-1}] * \in H^{p-1}(S^{p-1})$, viewed as the summand corresponding to $e \in E$, we can write the third map in this sequence as

$$\bigoplus_{v \in V} H^{p-1}(S_{\deg(v)}^p) \bigoplus_{u \in U} \pi_u^*(H^{p-1}(B_u)) \oplus Ra_u \longrightarrow \bigoplus_{e \in E} Re.$$

We denote this map by ϕ . By Lemma 3.16, for every $v \in V$, there are generators $a_{u_1 u_2}^v, u_1, u_2 \in U$ with $(u_1, v), (u_2, v) \in E$, of $H^{p-1}(S_{\deg(v)}^p)$ (note that they are not linearly independent), so that we have

$$\begin{aligned} \phi(a_{u_1 u_2}^v) &= \delta(u_1, v)(u_1, v) - \delta(u_2, v)(u_2, v), & \text{for } v \in V, \\ \phi(x) &= 0, & \text{for } x \in \pi_u^*(H^{p-1}(B_u)), u \in U, \\ \phi(a_u) &= \sum_{e=(u,v) \in E} e, & \text{for } u \in U. \end{aligned}$$

The last line follows from (2.6).

If G is the graph $(v) \overset{e}{\leftarrow} (u)$, then $S_{\deg(v)}^p$ is contractible, so $H^{p-1}(S_{\deg(v)}^p)$ is trivial and $\phi(a_u) = e$. Hence, the map ϕ is surjective with kernel $\pi_u^*(H^{p-1}(B_u))$.

Now suppose that no vertex in V is a leaf. Then, for any edge $e = (u, v) \in E$, that is connected to a leaf $u \in U$, we have $\phi(a_u) = e$. Hence, for any edge $e' = (u', v) \in E$ connected to v , we have

$$\phi(\delta(u', v)a_{u' u}^v + \delta(u, v)a_u) = e'.$$

Hence, by induction over the distance to the root, we see that the map ϕ is surjective.

We have that $\bigoplus_{u \in U} \pi_u^*(H^{p-1}(B_u))$ is contained in the kernel of ϕ . Further, the image of the restriction $\bigoplus_{v \in V} H^{p-1}(S_{\deg(v)}^p) \rightarrow \bigoplus_{e \in E} Re$ of ϕ is given by

$$\left\{ \sum_{e \in E} \lambda_e e \mid \lambda_e \in R \forall e \in E, \sum_{e=(u,v) \in E} \delta(e)\lambda_e = 0 \forall v \in V \right\}.$$

Thus, to determine the kernel of ϕ , we need to determine all elements $\sum_{u \in U} \lambda_u a_u \in \bigoplus_{u \in U} Ra_u$, that get mapped into this set via ϕ . This is precisely the set

$$\left\{ \sum_{u \in U} \lambda_u a_u \mid \lambda_u \in R \forall u \in U, \sum_{e=(u,v) \in E} \delta(e) \lambda_u = 0 \forall v \in V \right\},$$

which is the projection of the kernel of ϕ to $\bigoplus_{u \in U} Ra_u$. This finishes the proof. □

Lemma 3.18. *Suppose that G satisfies (3.3). Then, the inclusion $M_G \hookrightarrow X$ induces a surjective map $H^i(X) \rightarrow H^i(M_G)$ with kernel given by*

$$\ker(H^i(X) \rightarrow H^i(M_G)) = \begin{cases} \bigoplus_{v \in V} \left(\sum_{e=(u,v) \in E} \delta(e) \pi_u^* [B_u]^* \right) R, & i = q; \\ \left\{ \sum_{u \in U} \lambda_u [E_u]^* \mid \lambda_u \in R \forall u \in U, \sum_{u \in U} \lambda_u = 0 \right\}, & i = p + q - 1; \\ 0, & \text{else.} \end{cases}$$

Proof. By excision, the cohomology of the pair (X, M_G) is isomorphic to the cohomology of the pair

$$\left(\bigsqcup_{v \in V} D^q \times S^p_{\text{deg}(v)}, \bigsqcup_{v \in V} S^{q-1} \times S^p_{\text{deg}(v)} \right).$$

By the long exact sequence, this pair only has nonvanishing cohomology groups in degrees q and $p + q - 1$. We first consider degree q . The inclusion $X \hookrightarrow \overline{M}_G$ then gives the following commutative square:

$$\begin{array}{ccc} H^q(\overline{M}_G, M_G) & \longrightarrow & H^q(\overline{M}_G) \\ \downarrow & & \downarrow \\ H^q(X, M_G) & \longrightarrow & H^q(X) \end{array}$$

For this commutative diagram, we will now prove the following claims:

- (1) $H^q(\overline{M}_G, M_G) \cong \bigoplus_{u \in U} H_p(B_u) \oplus_{v \in V} Rv$ and $H^q(\overline{M}_G) \cong \bigoplus_{u \in U} Ru \oplus_{v \in V} H^q(S^p)$.
- (2) The map $H^q(\overline{M}_G, M_G) \rightarrow H^q(X, M_G)$ restricted to $\bigoplus_{v \in V} Rv$ is an isomorphism.
- (3) The map $H^q(\overline{M}_G, M_G) \rightarrow H^q(\overline{M}_G)$ maps $v \in V$ to $\sum_{e=(u,v) \in E} \delta(e)u$.
- (4) The map $H^q(\overline{M}_G) \rightarrow H^q(X)$ maps $u \in U$ to $\pi_u^* [B_u]^*$.

- (1) By Lefschetz duality, we have $H^q(\overline{M}_G, M_G) \cong H_p(\overline{M}_G)$, so both isomorphisms follow from the fact that \overline{M}_G is homotopy equivalent to $\bigvee_{u \in U} B_u \bigvee_{v \in V} S^p$.
- (2) We have the following commutative diagram of inclusions:

$$\begin{array}{ccc} \left(\bigsqcup_{v \in V} S^p_{\text{deg}(v)} \times D^q, \bigsqcup_{v \in V} S^p_{\text{deg}(v)} \times S^{q-1} \right) & \hookrightarrow & (X, M_G) \\ & \searrow & \downarrow \\ & & (\overline{M}_G, M_G) \end{array} \tag{3.5}$$

and Lefschetz duality gives the following commutative square:

$$\begin{array}{ccc}
 H^q(\overline{M}_G, M_G) & \longrightarrow & \bigoplus_{v \in V} H^q(S^p_{\deg(v)} \times D^q, S^p_{\deg(v)} \times S^{q-1}) \\
 \downarrow \cong & & \downarrow \cong \\
 H_p(\overline{M}_G) & \longrightarrow & \bigoplus_{v \in V} H_p(S^p_{\deg(v)} \times D^q, \bigsqcup_{\deg(v)} S^{p-1} \times D^q)
 \end{array}$$

The elements $v \in H^q(\overline{M}_G, M_G)$ in (1) are represented by $B_v \cong S^p \subseteq \overline{M}_G$ in $H_p(\overline{M}_G) \cong H^q(\overline{M}_G, M_G)$. Each class $[B_v]$ also represents a generator of

$$H_p\left(S^p_{\deg(v)} \times D^q, \bigsqcup_{\deg(v)} S^{p-1} \times D^q\right) \cong H_p\left(S^p, \bigsqcup_{\deg(v)} D^p\right) \cong H_p(S^p).$$

Hence, when restricted to $\bigoplus_{v \in V} Rv$, the lower horizontal map is an isomorphism. The claim now follows from the commutativity of (3.5) and that the map

$$\left(\bigsqcup_{v \in V} S^p_{\deg(v)} \times D^q, \bigsqcup_{v \in V} S^p_{\deg(v)} \times S^{q-1} \right) \hookrightarrow (X, M_G)$$

induces an isomorphism on cohomology by excision.

- (3) By Lefschetz duality, we have the following commutative diagram:

$$\begin{array}{ccc}
 H^q(\overline{M}_G, M_G) & \longrightarrow & H^q(\overline{M}_G) \\
 \downarrow \cong & & \downarrow \cong \\
 H_p(\overline{M}_G) & \longrightarrow & H_p(\overline{M}_G, M_G)
 \end{array}$$

By (1), for each $v \in V$, the element $v \in H^q(\overline{M}_G, M_G)$ maps to the homology class that is represented by $B_v \cong S^p \subseteq \overline{M}_G$. By isotoping the embedding of the zero-section $B_v \subseteq \overline{E}_v \subseteq \overline{M}_G$ to the boundary of the disc bundle (which is possible as the bundle π_v is trivial), we see that the class of this embedding in $H_p(\overline{M}_G, M_G)$ is represented by the sum of embeddings of fibers of all \overline{E}_u for which $(u, v) \in E$, each class multiplied by the sign $\delta(u, v)$. Each embedding of a fiber of \overline{E}_u represents the dual to the class represented by the embedding of the zero-section $B_u \subseteq \overline{E}_u$. By commutativity of the diagram, it follows that $v \in H^q(\overline{M}_G, M_G)$ gets mapped to $\sum_{e=(u,v) \in E} \delta(e)u \in H^q(\overline{M}_G)$.

- (4) The diagram of maps

$$\begin{array}{ccc}
 \bigsqcup_{u \in U} B_u & \hookrightarrow & \overline{M}_G \\
 \uparrow \sqcup_u \pi_u & & \uparrow \\
 \bigsqcup_{u \in U} E_u & \hookrightarrow & X
 \end{array}$$

induces the following commutative diagram, where the lower horizontal map is injective by Lemma 3.17.

$$\begin{array}{ccc}
 \bigoplus_{u \in U} H^q(B_u) & \longleftarrow & H^q(\overline{M}_G) \\
 \downarrow \bigoplus_u \pi_u^* & & \downarrow \\
 \bigoplus_{u \in U} H^q(E_u) & \longleftarrow & H^q(X)
 \end{array}$$

For each $u \in U$, the element $u \in H^q(\overline{M}_G)$ gets mapped to $[B_u]^* \in H^q(B_u)$, which, in turn, gets mapped to $\pi_u^*[B_u]^* \in H^q(E_u)$. This proves the claim.

Combining claims (1)–(4), it follows that the map $H^q(X, M_G) \rightarrow H^q(X)$ is given by

$$\begin{aligned}
 \bigoplus_{v \in V} Rv &\longrightarrow H^q(X) \subseteq \bigoplus_{u \in U} H^q(E_u) \\
 v &\longmapsto \sum_{e=(u,v) \in E} \delta(e) \pi_u^*[B_u]^*.
 \end{aligned}$$

This map is injective; this is clear if G is of the form $\bigcirc -^e - \bigcirc$. If no vertex is a leaf, then this follows from Lemma A.3.

To summarize, we showed for $i < p + q - 1$ that the map $H^i(X) \rightarrow H^i(M_G)$ is surjective except possibly for $i = p + q - 2$ and only has a nontrivial kernel when $i = q$, which is then generated by the elements $\sum_{e=(u,v) \in E} (\delta(e) \pi_u^*[B_u]^*)$ for $v \in V$.

It remains to consider the case $i = p + q - 1$. For each $u \in U$, we have the following commutative diagram of maps of pairs:

$$\begin{array}{ccc}
 (M_G, \emptyset) & \xrightarrow{\quad\quad\quad} & (X, \emptyset) \\
 \downarrow & & \uparrow \\
 \left(M_G, M_G \setminus \left(E_u \setminus \bigsqcup_{(u,v) \in E} \varphi_{(u,v)}(D^q \times S^{p-1}) \right) \right) & & (E_u, \emptyset) \\
 \uparrow & & \downarrow \\
 \left(E_u \setminus \bigsqcup_{(u,v) \in E} \varphi_{(u,v)}(D^q \times S^{p-1})^\circ, \bigsqcup_{(u,v) \in E} \varphi_{(u,v)}(S^{q-1} \times S^{p-1}) \right) & \xrightarrow{\quad\quad\quad} & \left(E_u, \bigsqcup_{(u,v) \in E} \varphi_{(u,v)}(D^q \times S^{p-1}) \right)
 \end{array}$$

The maps not involving X are all orientation-preserving maps that induce isomorphisms on H^{p+q-1} by excision and the long exact sequence. Hence, each $[E_u]^* \in H^{p+q-1}(X)$ gets mapped to the dual of the fundamental class of M_G under the induced map $H^{p+q-1}(X) \rightarrow H^{p+q-1}(M_G)$. In particular, the kernel of this map is given by

$$\left\{ \sum_{u \in U} \lambda_u [E_u]^* \mid \lambda_u \in U \ \forall u \in U, \sum_{u \in U} \lambda_u = 0 \right\}.$$

Further, by the long exact sequence of the pair

$$\left(\bigsqcup_{v \in V} S^p_{\text{deg}(v)} \times D^q, \bigsqcup_{v \in V} S^p_{\text{deg}(v)} \times S^{q-1} \right),$$

the R -module $H^{p+q-1}(X, M_G)$ is free of rank $|E| - |V|$. Since the kernel of the map

$$H^{p+q-1}(X) \longrightarrow H^{p+q-1}(M_G),$$

which is the image of the map $H^{p+q-1}(X, M_G) \rightarrow H^{p+q-1}(X)$, has rank $|U| - 1$, and since in a tree, we have $|U| + |V| = |E| + 1$, that is, $|E| - |V| = |U| - 1$, it follows that $H^{p+q-1}(X, M_G)$ injects into $H^{p+q-1}(X)$ as any surjective R -module homomorphism $R^{|U|-1} \rightarrow R^{|U|-1}$ is necessarily injective. This shows that the boundary map $H^{p+q-2}(M_G) \rightarrow H^{p+q-1}(X, M_G)$ is trivial, and hence, the map $H^{p+q-2}(X) \rightarrow H^{p+q-2}(M_G)$ is surjective. This finishes the proof. \square

We are now ready to prove Theorems 3.12 and 3.14 and Corollary 3.15.

Proof of Theorem 3.12. This directly follows from Lemmas 3.17 and 3.18. \square

Proof of Theorem 3.14. For $u \in U$, we have the inclusion $\bar{E}_u \hookrightarrow \bar{M}_G$, and, by naturality, the induced map on cohomology maps $c(T\bar{M}_G)$ to $c(T\bar{E}_u)$. If ξ_u denotes the vector bundle corresponding to π_u , then the tangent bundle of \bar{E}_u decomposes as

$$T\bar{E}_u \cong \pi_u^*(\xi_u \oplus TB_u),$$

cf. Proposition 2.5. Hence,

$$c(T\bar{E}_u) = \pi_u^*c(\xi_u \oplus TB_u).$$

Since $\bar{M}_G \simeq \bigvee_{u \in U} B_u \bigvee_{v \in V} B_v$ and all bundles π_v are trivial, it follows that

$$c(T\bar{M}_G) = \sum_{u \in U} c(T\bar{E}_u) = \sum_{u \in U} \pi_u^*c(\xi_u \oplus TB_u).$$

Now $M_G = \partial\bar{M}_G$, and we denote the inclusion $M_G \hookrightarrow \bar{M}_G$ by ι . Then,

$$\iota^*T\bar{M}_G \cong TM_G \oplus \underline{\mathbb{R}}_{M_G},$$

the trivial factor corresponding to the normal bundle of M_G in \bar{M}_G . Hence, by the stability of c , we have

$$c(TM_G) = \iota^* \left(\sum_{u \in U} \pi_u^*c(\xi_u \oplus TB_u) \right).$$

To determine this element in $H^*(M_G)$, consider the following commutative diagram:

$$\begin{array}{ccc} M_G & \hookrightarrow & X \longleftarrow \coprod_{u \in U} E_u \\ \downarrow \iota & & \downarrow \coprod_{u \in U} \pi_u \\ \bar{M}_G & \longleftarrow & \coprod_{u \in U} B_u \end{array}$$

By Theorem 3.12, we need to determine the image of $c(TM_G)$ in the cohomology of $\bigsqcup_{u \in U} E_u$. This is given by

$$\sum_{u \in U} \pi_u^* c(\xi_u \oplus TB_u) \in \bigoplus_{u \in U} H^*(E_u; R).$$

□

Proof of Corollary 3.15. In both cases, M_G is simply-connected by Lemma 3.10. By (2.4), we have that $\bigoplus_{u \in U} H^*(E_u; \mathbb{Z})$ has torsion-free homology. Since, by Lemma A.4, the subspace

$$\bigoplus_{v \in V} \left(\sum_{e=(u,v) \in E} \delta(e) \pi_u^* [B_u]^* \right) \mathbb{Z}$$

is a direct summand in $\bigoplus_{u \in U} H^q(E_u; \mathbb{Z})$, the same is true for $H^*(M_G; \mathbb{Z})$ by Theorem 3.12. The remaining claims directly follow from Theorems 3.12 and 3.14. □

4 | SIMPLY-CONNECTED $6k$ -DIMENSIONAL MANIFOLDS

In this section, we consider manifolds obtained by plumbing in dimension $6k$.

4.1 | The classification of Jupp

Recall from the introduction that we consider systems of invariants $(H^{2k}(M), \mu_M, w_2(M)^k, p_k(M))$ of a closed, simply-connected $6k$ -dimensional manifold M with torsion-free homology.

Two systems of invariants (H, μ, w, p) and (H', μ', w', p') are *equivalent* if there is an isomorphism $\phi : H \rightarrow H'$ such that $\phi^* \mu' = \mu$, $\phi(w) = w'$ and $\phi^* p' = p$. It is then clear that two manifolds that are orientation-preserving diffeomorphic have equivalent systems of invariants.

A system of invariants is called *admissible in dimension $6k$* if it is the system of invariants of a closed, simply-connected and oriented $6k$ -dimensional manifold with torsion-free homology. With this terminology, for $k = 1$, the classification of Jupp is then given as follows.

Theorem 4.1 [13, Theorem 1]. *Two oriented closed simply-connected 6-manifolds M and M' are orientation-preserving diffeomorphic if and only if $b_3(M) = b_3(M')$ and their systems of invariants are equivalent. A system of invariants (H, μ, w, p) is admissible in dimension 6 if and only if*

$$\mu(W) \equiv p(W) \pmod{48} \tag{4.1}$$

holds for all $W \in H$ whose reduction to $H \otimes \mathbb{Z}/2$ is w .

For $k > 1$, due to the much larger range of (co-)homology groups, one needs to consider and since there can exist exotic spheres, there is no such classification possible.

Theorem 4.1 is commonly referred to as the classification of closed, simply-connected 6-manifolds with torsion-free homology. It should be noted that the term “classification” can

be misleading in this context: in fact, Jupp’s result shows that the classification of closed, simply-connected 6-manifolds with torsion-free homology is *equivalent* to the classification of equivalence classes of systems of invariant that satisfy (4.1) and there is no classification known of the latter, except if $\text{rk}(H) = 1$ (this is obvious) or if $\text{rk}(H) = 2$, in which case there exists a partial classification by Schmitt [22].

We also note that Jupp’s classification extends the classification of Wall [28], which requires the manifolds to be spin, and is a special case of the classification of Zhubr [29], which does not require the manifolds to have torsion-free homology.

4.2 | Algebraic plumbing graphs

In this section, we introduce the notion of algebraic plumbing graphs and give the proof of Theorem A.

Let $G = (U, V, E, (\alpha, k^+, k^-))$ be a bipartite graph, which has a labeling $(\alpha, k^+, k^-) : U \rightarrow \mathbb{Z} \times \mathbb{N}_0^2$ for vertices in U . We call such a graph an *algebraic plumbing graph*. We will draw vertices $u \in U$ as

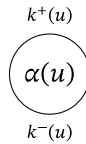

If one of $k^+(u)$ and $k^-(u)$ vanishes, then we will omit it. Vertices in V will be drawn as dots (as they do not have any labeling). An example for such a graph is the graph given in the introduction.

For every $u \in U$, we introduce the symbols $u^{-k^-(u)}, \dots, u^{k^+(u)}$ and define the free abelian group

$$A = \bigoplus_{u \in U} \bigoplus_{i=-k^-(u)}^{k^+(u)} \mathbb{Z}u^i.$$

For $k \in \mathbb{N}$, we define the symmetric trilinear form $\mu^k : A^3 \rightarrow \mathbb{Z}$ by defining it for each $u \in U$ on $\bigoplus_{i=-k^-(u)}^{k^+(u)} \mathbb{Z}u^i$ by

$$\begin{aligned} \mu^k(u^0, u^0, u^0) &= \frac{\lambda_k}{4} \alpha(u), \\ \mu^k(u^0, u^0, u^l) &= 0, \\ \mu^k(u^0, u^j, u^l) &= \begin{cases} \text{sgn}(j), & j = l, \\ 0, & \text{else,} \end{cases} \\ \mu^k(u^i, u^j, u^l) &= 0 \end{aligned}$$

for $i, j, l \in \{-k^-(u), \dots, k^+(u)\} \setminus \{0\}$, where $\lambda_k \in \mathbb{N}$ is the constant from Lemma 2.9 (note that it is a multiple of 4 by definition). Then extend μ^k to A by setting

$$\mu^k(u_m^i, u_n^j, u_r^k) = 0$$

whenever any two of u_m, u_n, u_r are not equal.

Next, we define a linear form $p^k : A \rightarrow \mathbb{Z}$ by

$$p^k(u^j) = \begin{cases} \lambda_k \alpha(u) + \binom{2k+1}{k} (k^+(u) - k^-(u)), & j = 0, \\ 0, & \text{else,} \end{cases}$$

and we define $w_G \in A \otimes \mathbb{Z}/2$ by

$$w_G = \sum_{\substack{u \in U, \\ i \neq 0}} u^i \pmod{2}.$$

Finally, we set

$$H_G = \bigoplus_{\substack{u \in U \\ i \neq 0}} \mathbb{Z}u^i \oplus \left\{ \sum_{u \in U} \lambda_u \cdot u^0 \mid \lambda_u \in \mathbb{Z} \forall u \in U, \sum_{e=(u,v) \in E} \lambda_u = 0 \forall v \in V \right\} \subseteq A$$

and denote the restrictions of μ^k and p^k to H_G by μ_G^k and p_G^k , respectively (and note, that, by definition, we have $w_G \in H_G \otimes \mathbb{Z}/2$). Further, we set $\mu_G = \mu_G^1$ and $p_G = p_G^1$.

Definition 4.2. We call $H_G, \mu_G^k, w_G,$ and p_G^k the *invariants of G* and we define the *rank of G* by $\text{rank}(H_G)$. We say that G is *spin* if $k^+ = k^- \equiv 0$. Two algebraic plumbing graphs G and G' are *k -equivalent*, denoted as $G \sim_k G'$, if the systems of invariants $(H_G, \mu_G^k, w_G, p_G^k)$ and $(H_{G'}, \mu_{G'}^k, w_{G'}, p_{G'}^k)$ are equivalent.

Remark 4.3. In the spin case, if two algebraic plumbing graphs are k -equivalent for one k , then they are k -equivalent for all k , since then $\mu_G^k = \frac{\lambda_k}{4} \mu_G$ and $p_G^k = \frac{\lambda_k}{4} p_G$ (recall that $\lambda_1 = 4$). However, in the nonspin case, it is not clear if k -equivalence for one k implies k -equivalence for other, or all, k .

Definition 4.4. We define a geometric plumbing graph $\overline{G}^k = (U, V, E, \pi, \delta)$ with the same set of vertices and edges as G as follows. For $u \in U$, set

$$B_u = \#_{k^+(u)} \mathbb{C}P^{2k} \#_{k^-(u)} (-\mathbb{C}P^{2k})$$

(note that the empty connected sum is defined as S^{4k}) and define π_u as the disc bundle of the bundle $\pi_{\alpha(u), B_u}$ of Definition 2.8. For $v \in V$, set $B_v = S^{2k+1}$ and define π_v as the trivial D^{4k} -bundle over S^{2k+1} , that is, $\overline{E}_v = S^{2k+1} \times D^{4k}$ and π_v is given by the projection onto the first factor. Finally, we define $\delta(e) = 1$ for all $e \in E$. We set $\overline{G} = \overline{G}^1$.

Remark 4.5. For $k > 2$, the definition of each bundle $\pi_{\alpha(u), B_u}$, and therefore the definition of \overline{G}^k , depends on a choice of preimage in Definition 2.8. As noted after Definition 2.8, the results of this article hold for any choice of such preimage.

Lemma 4.6. *Let $G = (U, V, E, (\alpha, k^+, k^-))$ be an algebraic plumbing graph for which all connected components are simply-connected and set $M = M_{\overline{G}^k}$. Then,*

- (1) *M is a closed, simply-connected $6k$ -dimensional manifold with torsion-free homology and the systems of invariants $(H^{2k}(M), \mu_M, w_2^k(M), p_k(M))$ and $(H_G, \mu_G^k, w_G, p_G^k)$ are equivalent. In particular, the system $(H_G, \mu_G^k, w_G, p_G^k)$ is admissible in dimension $6k$.*
- (2) *There exists a k -equivalent subgraph G' of G so that for $M' = M_{\overline{G}'^k}$, the same as in (1) holds and additionally the odd Betti numbers of M' vanish and $M = M' \#_r (S^{2k+1} \times S^{4k-1})$ for some $r \in \mathbb{N}_0$.*
- (3) *$b_{2k}(M') = b_{2k}(M) = |U'| - |V'| + \sum_{u \in U'} k^+(u) + k^-(u)$.*
- (4) *M is spin if and only if G is spin, and the same holds for M' and G' (and note that M is spin if and only if M' is spin by (2)).*

Proof. We use Proposition 3.3 to split \overline{G}^k into connected components that either satisfy the hypotheses of Theorem 3.12 or consist of a single vertex in V as follows: For any $u \in U$ that is connected to a leaf, we remove all edges connected to u except one that connects u to a leaf, this is precisely the modification in Proposition 3.3. The corresponding modification of G does not change its invariants, since for such u , we always have that u^0 has coefficient zero in every element of H_G . We repeat this process until all connected components of \overline{G}^k satisfy the hypotheses of Theorem 3.12 and we denote the graph we obtain from G in this way after additionally removing all isolated vertices in V by G' . Then, G and G' have the same invariants, since isolated vertices in V do not make any contribution, and the manifolds M and M' then only differ by connected sums of copies of $S^{2k+1} \times S^{4k-1}$.

By Corollary 3.15, the cohomology group $H^{2k}(M)$ is given by

$$H^{2k}(M) = \bigoplus_{u \in U} \pi_u^* H^{2k}(B_u) \oplus \left\{ \sum_{u \in U} \lambda_u \cdot a_u \mid \lambda_u \in \mathbb{Z} \forall u \in U, \sum_{e=(u,v) \in E'} \delta(e) \lambda_u = 0 \forall v \in V' \right\},$$

and we define the isomorphism $\phi : H^{2k}(M) \rightarrow H_{G'}$ by mapping a generator of the i th summand in the first component of the right-hand side of

$$H^{2k}(B_u) = \bigoplus_{k^+(u)} H^{2k}(\mathbb{C}P^{2k}) \bigoplus_{k^-(u)} H^{2k}(-\mathbb{C}P^{2k})$$

to u^i and a generator of the i th summand in the second component of the right-hand side to u^{-i} . Further, we define

$$\phi \left(\sum_{u \in U} \lambda_u \cdot a_u \right) = \sum_{u \in U} \lambda_u u^0.$$

It now follows from Theorem 3.12 and Corollary 2.13, that this isomorphism preserves the remaining invariants. Moreover, it follows from (2.4) that $\bigoplus_{u \in U} H^*(E_u)$ is trivial in odd degrees, and by Theorem 3.12, the same holds for $H^*(M')$.

For (3), we need to determine the rank of

$$\left\{ \sum_{u \in U} \lambda_u \cdot u^0 \mid \lambda_u \in \mathbb{Z} \forall u \in U, \sum_{e=(u,v) \in E'} \lambda_u = 0 \forall v \in V' \right\} \subseteq H_{G'}.$$

The condition for the coefficients λ_u is equivalent to $(\lambda_u)_{u \in U}$ being an element of the kernel of $B(G')^T$ (see the Appendix). By Lemma A.3, the matrix $B(G')$ has rank $|V'|$ (as $|U'| \geq |V'|$), hence its kernel has rank $|U'| - |V'|$.

Finally, for (4), note that by (1), w_G (and $w_{G'}$) vanishes if and only if $w_2(M)^k$ (and $w_2(M')^k$) vanishes, which is the case if and only if $w_2(M)$ (and $w_2(M')$) vanishes by the cohomology ring structure of each E_u . □

We can now prove Theorem A.

Proof of Theorem A. First consider an arbitrary algebraic plumbing graph G . By construction, the group H_G is a subgroup of A and the invariants μ_G and p_G are the restrictions of the invariants μ^1 and p^1 . Let G^0 be the graph obtained from G by removing all edges. Then, the invariants of G^0 are precisely A, μ^1, w_G , and p^1 and the system of invariants (A, μ^1, w_G, p^1) is realized by M_{G^0} by (1) of Lemma 4.6. It follows that (4.1) holds for all $W \in A$, and hence also for all $W \in H_G$, that restrict to w_G . Thus, the system (H_G, μ_G, w_G, p_G) is admissible in dimension 6.

Now assume that every connected component of G is simply-connected and let $M = M_{G^k}$. We apply Lemma 4.6 to obtain an equivalent subgraph G' of G and a manifold $M' = M_{G'^k}$ with vanishing odd cohomology. Since each connected component of G' is simply-connected, we can apply Theorem 1.1 to obtain a core metric on each summand of M' , hence M' also admits a core metric, but note that if $k = 1$, then the restrictions on the dimensions in this theorem require that every connected component contains a vertex in V . This can always be achieved by introducing a new vertex according to Proposition 3.5. Since $M = M' \#_r (S^{2k+1} \times S^{4k-1})$ for some $r \in \mathbb{N}_0$, and $S^{2k+1} \times S^{4k-1}$ admits a core metric (see the list in Subsection 2.1), M admits a core metric.

Finally, if $k = 1$ and N is a simply-connected 6-manifold with torsion-free homology, whose invariants are equivalent to (H_G, μ_G, w_G, p_G) , then, by Theorem 4.1, N is diffeomorphic to $M' \#_r (S^3 \times S^3)$ for some $r \in \mathbb{N}_0$, so N admits a core metric. □

4.3 | Reduced Graphs

A fixed system of invariants (H, μ, w, p) can potentially be realized by many different algebraic plumbing graphs. To analyze this, we consider modifications of graphs that do not change the invariants.

Lemma 4.7. *We can modify algebraic plumbing graphs in the following ways without changing their k -equivalence classes.*

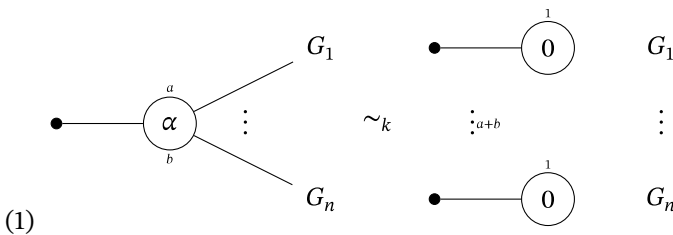

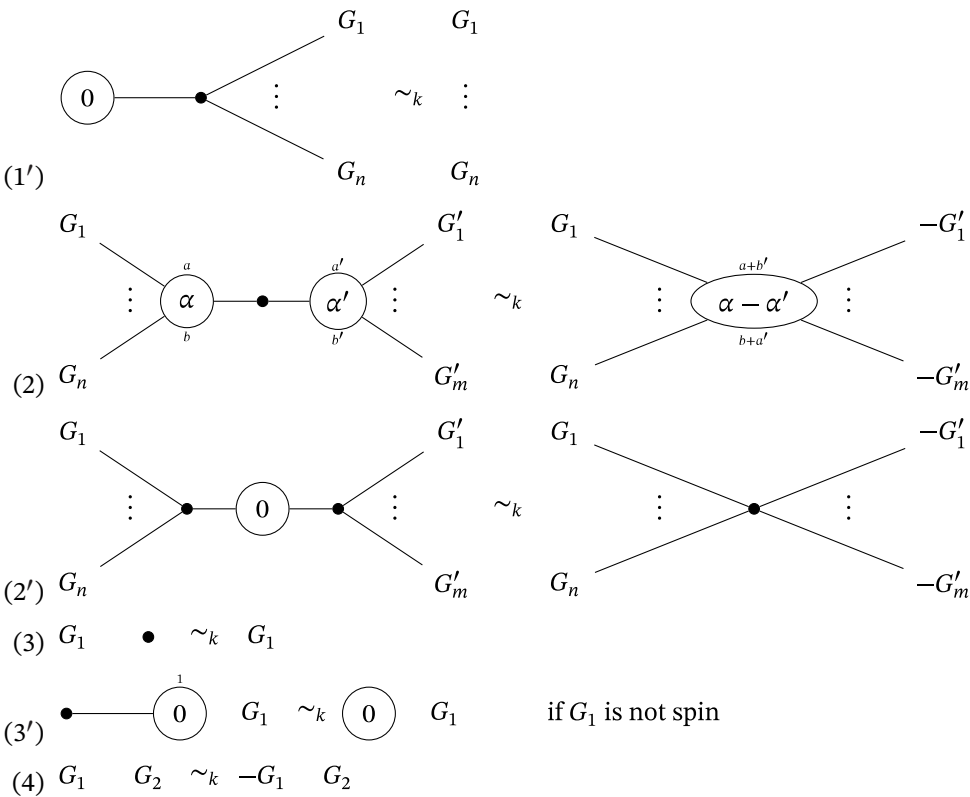

Here, G_i, G'_i are (pairwise disjoint, and possibly empty) subgraphs, and $-G$ denotes G with α replaced by $-\alpha$ and (k^+, k^-) replaced by (k^-, k^+) .

Proof. First note that $\overline{-G}^k$ is obtained from \overline{G}^k by reversing the orientations of all bases and fibers (but not of the total spaces). Then, the equivalences (3) and (4) are clear and the remaining equivalences follow from Propositions 3.2, 3.3, and 3.5 and Lemma 4.6, except (1) and (3'). For (1), we additionally need to show that

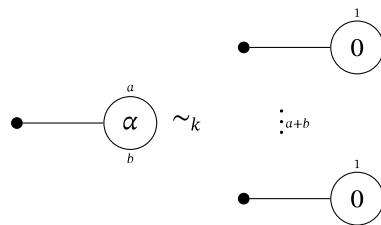

holds. For that, denote the graph on the left-hand side by G and the graph on the right-hand side by G' . Denote the single element of U by u and the elements of U' by u_1, \dots, u_{a+b} . Then, by definition, we have

$$H_G = \bigoplus_{\substack{i=-b \\ i \neq 0}}^a \mathbb{Z}u^i \quad \text{and} \quad H_{G'} = \bigoplus_{i=1}^{a+b} \mathbb{Z}u_i^1,$$

and an isomorphism $H_G \rightarrow H_{G'}$ is given by mapping u^i to u_i^1 for $i > 0$ and u^i to u_{a-i}^1 for $i < 0$. It is now easily verified that $\mu_G^k, p_G^k, \mu_{G'}^k$ and $p_{G'}^k$ all vanish, and that

$$w_G = \sum_{\substack{u \in U, \\ i \neq 0}} u^i \pmod 2, \quad w_{G'} = \sum_{i=1}^{a+b} u_i^1 \pmod 2,$$

hence this isomorphism preserves all invariants.

For (3'), denote the graph on the left-hand side by G and the one on the right-hand side by G' . Let $x_0 \in H_{G_1}$ be a primitive element that restricts to w_{G_1} (which exists since w_{G_1} is nontrivial) and extend it to a basis (x_0, \dots, x_n) of H_{G_1} . Let u_1 be the additional vertex in U and u_2 the additional vertex in U' . Then

$$w_G = u_1^1 + x_0 \pmod 2, \quad w_{G'} = x_0 \pmod 2.$$

Hence, by mapping u_1^1 to u_2^0, x_0 to $x_0 - u_2^0$ and x_i to x_i for $i > 0$, we obtain an isomorphism $H_G \rightarrow H_{G'}$ that maps w_G to $w_{G'}$. Since the linear and trilinear forms are only nontrivial on elements of H_{G_1} , they are also preserved under this isomorphism. \square

These modifications will be used to bring a given graph into a reduced form.

Definition 4.8. Let $G = (U, V, E, (\alpha, k^+, k^-))$ be an algebraic plumbing graph. We call G *reduced*, if it satisfies the following conditions:

- Every connected component of G is simply-connected.
- The graph $\bullet \text{---} \textcircled{0}$ only appears as a connected component in G if it is the only nonspin connected component. Every $v \in V$ not contained in this connected component has degree at least 3.
- Every $u \in U$ with $\alpha(u) = k^+(u) = k^-(u) = 0$ has degree 0 or at least 3.

Given a reduced graph G , we define its *reduced class* as the set of isomorphism classes of reduced graphs that are obtained from G by multiplying each connected component by (± 1) . By (4) of Lemma 4.7, two reduced graphs with the same reduced class are k -equivalent, so the notion of k -equivalence descends to an equivalence relation between reduced classes.

The following result is now a direct consequence of Lemmas 4.6 and 4.7.

Corollary 4.9. Let $G = (U, V, E, (\alpha, k^+, k^-))$ be an algebraic plumbing graph. If every connected component of G is simply-connected, then G is k -equivalent to a reduced graph G' . Further, we have $\text{rank}(H_G) = |U'| - |V'| + \sum_{u \in U'} k^+(u) + k^-(u)$.

It is now a natural question, how “good” this notion of reduced form is, that is, if any two k -equivalent reduced graphs are contained in the same reduced class.

Question 4.10. Let G_1, G_2 be reduced graphs that are k -equivalent for some k . Are their reduced classes the same?

This question is open, but we will answer it affirmatively in some special cases. For that, we first list the reduced graphs of low rank. Clearly, the only reduced graph of rank 0 is the empty graph, which defines S^6 .

Proposition 4.11. *Let G be a reduced graph of rank 1. Then the following assertions hold:*

- If G is spin, then it is of the form $\textcircled{\alpha}$. The manifold $M_{\overline{G}}^k$ is the total space of a linear S^{2k} -bundle over S^{4k} . Two graphs $\textcircled{\alpha_1}$ and $\textcircled{\alpha_2}$ are k -equivalent if and only if $\alpha_1 = \pm\alpha_2$.
- If G is not spin, then it is given by $\bullet \text{---} \overset{1}{\textcircled{0}}$. The graph G has trivial trilinear form μ_G^k and trivial linear form p_G^k . If $k = 1$, then the manifold $M_{\overline{G}}$ is the unique nontrivial linear S^4 -bundle over S^2 .

Proposition 4.12. *Let G be a reduced graph of rank 2. Then, the following assertions hold:*

- If G is spin, then it is of the form

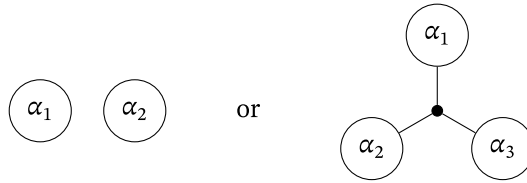

with $\alpha_i \neq 0$ in the second case. For every such graph G , there is at most one reduced class that is k -equivalent but not equal to that of G .

- If G is not spin, its reduced class is equal to that of a graph of the form

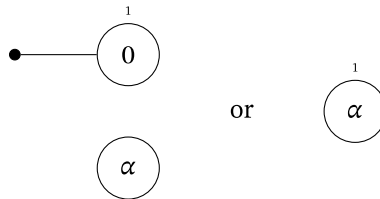

For every such graph G , every reduced class that is k -equivalent to that of G is equal to that of G .

We refer to [19, Proposition 6.4.3] for a list of reduced graphs of rank 3.

The possibilities for the reduced graphs are a simple combinatorial consequence of the following lemma.

Lemma 4.13. *Let G' be a nonempty connected component of a reduced graph that is not of the form $\bullet \text{---} \overset{1}{\textcircled{0}}$. Then,*

$$2 \cdot |V'| + 1 \leq |U'|.$$

Proof. If V' is empty, then the inequality holds trivially. If V' is nonempty, then, since G' is simply-connected, we can choose a root $v_0 \in V'$ and consider it as a tree. Then, the inequality follows from the fact that, by definition, v_0 has at least three descending vertices in U' , while every other $v \in V'$ has at least 2. □

It follows from Lemma 4.13 and Corollary 4.9 that for a connected component G' of a reduced graph, which is not of the form $\bullet \text{---} \textcircled{0}$, we have

$$\text{rank}(H_{G'}) = |U'| - |V'| + \sum_{u \in U'} k^+(u) + k^-(u) \geq 1 + |V'| + \sum_{u \in U'} k^+(u) + k^-(u).$$

Thus, $\text{rank}(H_{G'}) = 1$ implies that V' is empty and $k^+ = k^- \equiv 0$. In a similar way, by going through all possibilities, we obtain the reduced forms in Proposition 4.12. It remains to prove the statements about k -equivalence in Propositions 4.11 and 4.12.

Proof of Proposition 4.11. If G is not of the form $\bullet \text{---} \textcircled{0}$, then G is given by $\textcircled{\alpha}$, which, by construction, yields the linear S^{2k} -bundle over S^{4k} corresponding to α .

For such a graph G , let $u \in U$ be the unique element. Then, $H_G = \mathbb{Z}u^0$ and

$$\mu(u^0, u^0, u^0) = \frac{\lambda_k}{4} \alpha = -\mu(-u^0, -u^0, -u^0).$$

Since u^0 and $-u^0$ are the only generators of H_G , this shows that for different absolute values of α , we obtain nonequivalent trilinear forms.

In the nonspin case, the manifold M_G^- is diffeomorphic to the unique nontrivial S^4 -bundle over S^2 by [20, Lemma 4.2]. □

Proof of Proposition 4.12. In the nonspin case, the linear form p_G^k of the first graph is given by $p_G^k(u_1^1) = 0$, $p_G^k(u_2^0) = \lambda_k \alpha$ (where u_1 denotes the upper vertex and u_2 the lower one), while the linear form on the second graph is given by $p_G^k(u^0) = \lambda_k \alpha + \binom{2k+1}{k}$, $p_G^k(u^1) = 0$, in particular, this is always nonzero. Since $\lambda_k > \binom{2k+1}{k}$, see Remark 2.10, this shows that for different (absolute) values of α , we obtain nonequivalent graphs.

In the spin case, we first consider the case $k = 1$. The first graph is k -equivalent to a graph of the second form with $\alpha_3 = 0$; therefore, it is enough to consider graphs of the second form, allowing $\alpha_i = 0$. Let G be such a graph. Then, $e_1 = u_1^0 - u_3^0$ and $e_2 = u_2^0 - u_3^0$ form a basis of H_G (where u_i denotes the vertex labeled by α_i) and we have

$$\begin{aligned} \mu_G(e_1, e_1, e_1) &= \alpha_1 - \alpha_3, \\ \mu_G(e_1, e_1, e_2) &= -\alpha_3, \\ \mu_G(e_1, e_2, e_2) &= -\alpha_3, \\ \mu_G(e_2, e_2, e_2) &= \alpha_2 - \alpha_3, \\ p_G(e_1) &= 4(\alpha_1 - \alpha_3), \\ p_G(e_2) &= 4(\alpha_2 - \alpha_3). \end{aligned}$$

We define homogeneous polynomials f and p by setting $f(x_1, x_2) = \mu_G(x, x, x)$, and $p(x_1, x_2) = \frac{1}{4} p_G(x)$, $x = x_1 e_1 + x_2 e_2$ and $x_1, x_2 \in \mathbb{C}$. We obtain

$$\begin{aligned} f(x_1, x_2) &= (\alpha_1 - \alpha_3)x_1^3 - 3\alpha_3 x_1^2 x_2 - 3\alpha_3 x_1 x_2^2 + (\alpha_2 - \alpha_3)x_2^3, \\ p(x_1, x_2) &= (\alpha_1 - \alpha_3)x_1 + (\alpha_2 - \alpha_3)x_2. \end{aligned}$$

Given two systems of invariants $(H_1, \mu_1, 0, p_1)$ and $(H_2, \mu_2, 0, p_2)$ with $\text{rank}(H_1) = \text{rank}(H_2) = n$ for which there is an isomorphism $\phi : H_1 \rightarrow H_2$ with $\phi^* \mu_2 = \mu_1$ and $\phi^* p_2 = p_1$, the associated pairs of homogeneous polynomials (f_1, p_1) and (f_2, p_2) for fixed bases E_1 and E_2 of H_1 and H_2 , respectively, satisfy

$$f_1(v) = f_2(A^T \cdot v) \quad \text{and} \quad p_1(v) = p_2(A^T \cdot v)$$

for all $v \in \mathbb{C}^n, n = \text{rank}(H_{G_1})$. Here, $A \in \mathbb{C}^{n \times n}$ is the matrix that transforms the basis E_2 into $\phi_* E_1$. In particular, $A \in \text{GL}(n, \mathbb{Z}) \subseteq \widetilde{\text{SL}}(n, \mathbb{C})$, where

$$\widetilde{\text{SL}}(n, \mathbb{C}) = \{A \in \text{GL}(n, \mathbb{C}) \mid \det(A) = \pm 1\}.$$

It follows that if two graphs are 1-equivalent, then the associated pairs of homogeneous polynomials lie in the same orbit of the action of $\widetilde{\text{SL}}(n, \mathbb{C})$.

For a given pair (f, p) of binary homogeneous polynomials, where f has degree 3 and p has degree 1, by [22, Section 3.1], there are invariants, that is, homogeneous polynomials in the coefficients of f and p that are invariant under the action of $\widetilde{\text{SL}}(2, \mathbb{C})$, given by $D(f), R(f, p)^2, I(f \cdot p)$, and $J(f \cdot p)$, where

- $D(f)$ is the discriminant of f ,
- $R(f, p)$ is the resultant of the pair (f, p) , and
- $I(f \cdot p)$ and $J(f \cdot p)$ are binary quartic polynomials.

For the precise definition of these invariants, we refer to [22, Section 3.1]. In our case, these are given as follows:

$$\begin{aligned} D(f) &= \alpha_1^2 \alpha_2^2 + \alpha_1^2 \alpha_3^2 + \alpha_2^2 \alpha_3^2 - 2\alpha_1^2 \alpha_2 \alpha_3 - 2\alpha_1 \alpha_2^2 \alpha_3 - 2\alpha_1 \alpha_2 \alpha_3^2, \\ R(f, p) &= (\alpha_1 - \alpha_3)(\alpha_2 - \alpha_3)(\alpha_2 - \alpha_1)(\alpha_1 + \alpha_2 + \alpha_3), \\ I(f \cdot p) &= \alpha_1^2 \alpha_2^2 + \alpha_1^2 \alpha_3^2 + \alpha_2^2 \alpha_3^2 - \alpha_1^2 \alpha_2 \alpha_3 - \alpha_1 \alpha_2^2 \alpha_3 - \alpha_1 \alpha_2 \alpha_3^2, \\ J(f \cdot p) &= -\alpha_1^4 \alpha_2^2 - \alpha_1^2 \alpha_2^4 - \alpha_1^4 \alpha_3^2 - \alpha_1^2 \alpha_3^4 - \alpha_2^4 \alpha_3^2 - \alpha_2^2 \alpha_3^4 + 2\alpha_1^4 \alpha_2 \alpha_3 + 2\alpha_1 \alpha_2^4 \alpha_3 + 2\alpha_1 \alpha_2 \alpha_3^4 \\ &\quad + \alpha_1^3 \alpha_2^2 \alpha_3 + \alpha_1^3 \alpha_2 \alpha_3^2 + \alpha_1^2 \alpha_2^3 \alpha_3 + \alpha_1 \alpha_2^3 \alpha_3^2 + \alpha_1^2 \alpha_2 \alpha_3^3 + \alpha_1 \alpha_2^2 \alpha_3^3 - 6\alpha_1^2 \alpha_2^2 \alpha_3^2. \end{aligned}$$

Note that $D(f), R(f, p)^2, I(f \cdot p)$, and $J(f \cdot p)$ are symmetric when viewed as polynomials in $(\alpha_1, \alpha_2, \alpha_3)$, hence we can express them in terms of the elementary symmetric polynomials

$$\begin{aligned} \sigma_1 &= \alpha_1 + \alpha_2 + \alpha_3, \\ \sigma_2 &= \alpha_1 \alpha_2 + \alpha_1 \alpha_3 + \alpha_2 \alpha_3, \\ \sigma_3 &= \alpha_1 \alpha_2 \alpha_3, \end{aligned}$$

and we obtain

$$\begin{aligned} D(f) &= \sigma_2^2 - 4\sigma_1 \sigma_3, \\ R(f, p)^2 &= \sigma_1^2 (\sigma_1^2 \sigma_2^2 - 4\sigma_2^3 - 4\sigma_1^3 \sigma_3 + 18\sigma_1 \sigma_2 \sigma_3 - 27\sigma_3^2), \end{aligned}$$

$$I(f \cdot p) = \sigma_2^2 - 3\sigma_1\sigma_3,$$

$$J(f \cdot p) = -\sigma_1^2\sigma_2^2 + 2\sigma_2^3 + 4\sigma_1^3\sigma_3 - 9\sigma_1\sigma_2\sigma_3.$$

Hence, the values of σ_2^2 , in particular, the value of σ_2 up to sign, and $\sigma_1\sigma_3$ are determined by $D(f)$ and $I(f \cdot p)$. We distinguish two cases.

Case 1. Assume that at least one of $D(f)$ and $I(f \cdot p)$ is nonzero. We now show that there are at most two triples $(\alpha_1, \alpha_2, \alpha_3)$ (up to permutation and simultaneous multiplication by (-1)) with invariants given by $(D(f), R(f, p)^2, I(f \cdot p), J(f \cdot p))$.

Indeed, from the expression for $J(f \cdot p)$, we obtain

$$(4\sigma_1\sigma_3 - \sigma_2^2)\sigma_1^2 + \sigma_2(2\sigma_2^2 - 9\sigma_1\sigma_3) - J(f \cdot p) = 0.$$

Since the values of σ_2^2 and $\sigma_1\sigma_3$ are determined by $D(f)$ and $I(f \cdot p)$, we consider these values as fixed and obtain a quadratic equation in σ_1 with no linear term. Hence, if $D(f) \neq 0$, then for every choice of sign for σ_2 , we obtain, up to sign, at most one solution for σ_1 . If $D(f) = 0$ and $I(f \cdot p) \neq 0$, and thus, $\sigma_2^2, \sigma_1\sigma_3 \neq 0$, then from the expression for $R(f, p)^2$, we obtain

$$(2\sigma_1\sigma_2\sigma_3)\sigma_1^2 - (27\sigma_1^2\sigma_3^2 + R(f, p)^2) = 0$$

and as before, every choice of sign for σ_2 uniquely determines σ_1 up to sign. The values for $\alpha_1, \alpha_2, \alpha_3$ are then obtained as the solutions of the equation

$$y^3 - \sigma_1 y^2 + \sigma_2 y - \sigma_3 = 0$$

and choosing a different sign for σ_1 (and thus also for σ_3) results in a simultaneous change of sign for the α_i .

Case 2. Assume that $D(f)$ and $I(f \cdot p)$ both vanish. We now show that in this case, at least two of the α_i vanish and the third one can be determined up to sign from the $\widetilde{\text{SL}}(2, \mathbb{C})$ -orbit of (f, p) .

Indeed, we have $\sigma_2^2 = \sigma_1\sigma_3 = 0$, which implies $\sigma_1 = 0$ or $\sigma_3 = 0$. If $\sigma_1 = 0$, then $\alpha_3 = -\alpha_1 - \alpha_2$, so

$$0 = \sigma_2 = -\alpha_1^2 - \alpha_1\alpha_2 - \alpha_2^2 = -\frac{1}{2}(\alpha_1^2 + \alpha_2^2 + (\alpha_1 + \alpha_2)^2),$$

which implies $\alpha_1 = \alpha_2 = 0$ and hence also $\alpha_3 = 0$. If $\sigma_3 = 0$, then one α_i , say α_3 , vanishes. Then, $\sigma_2 = \alpha_1\alpha_2$, hence also one of α_1, α_2 , say α_2 , vanishes.

To determine the value of α_1 under the assumption $\alpha_2 = \alpha_3 = 0$, first note that α_1 vanishes if and only if f is trivial. If f is nontrivial, we have that f divides p^3 with quotient α_1^2 . In particular, the value of α_1 can be determined up to sign from the $\widetilde{\text{SL}}(2, \mathbb{C})$ -orbit of (f, p) .

Thus, we have shown that for any pair of binary homogeneous polynomials (f, p) , where f has degree 3 and p has degree 1, there are at most two triples $(\alpha_1, \alpha_2, \alpha_3)$ (up to permutation and

simultaneous multiplication by (-1)) whose associated pairs of polynomials are in the $\widetilde{SL}(2, \mathbb{C})$ -orbit of (f, p) .

Since in the spin case $(\mu_G^k, p_G^k) = \frac{\lambda_k}{4}(\mu_G, p_G)$ holds, this result carries over to k -equivalence for all k . □

Remark 4.14. We conjecture that Proposition 4.12 can be improved to give a positive answer to Question 4.10 for reduced graphs of rank 2. In fact, there are many special cases where for given values $(D, R^2, I, J) \in \mathbb{Z}^4 \setminus \{0\}$ in the proof of Proposition 4.12, there exists only one triple $(\alpha_1, \alpha_2, \alpha_3) \in \mathbb{Z}^3$ with $D(f) = D, R(f, p)^2 = R^2, I(f \cdot p) = I$ and $J(f \cdot p) = J$, see [19, Remark 6.4.5]. As a result, we obtain an affirmative answer to Question 4.10 for graphs defined by these values $(\alpha_1, \alpha_2, \alpha_3)$. These cases include the following:

- (1) $\alpha_1 + \alpha_2 + \alpha_3 = 0$,
- (2) $\alpha_1\alpha_2 + \alpha_1\alpha_3 + \alpha_2\alpha_3 = 0$,
- (3) One α_i vanishes,
- (4) Two of the α_i equal -1 .
- (5) $\alpha_1, \alpha_2, \alpha_3 \in [-1000, 1000]$.

On the other hand, the strategy of the proof of Proposition 4.12 cannot be extended to provide a proof of Question 4.10 for reduced graphs of rank 2. In fact, there are triples $(\alpha_1, \alpha_2, \alpha_3)$ and $(\alpha'_1, \alpha'_2, \alpha'_3)$, which are not related via a permutation or simultaneous multiplication by (-1) , but whose invariants D, R, I , and J are all the same, see [19, Remark 6.4.5]. This occurs for example for the triples

$$(4, 15, 30) \quad \text{and} \quad (-6, -5, 60).$$

By bringing the associated homogeneous polynomials in a canonical form as in [22, Section 3.4], one sees that the corresponding systems of invariants are not equivalent; thus, they do not provide counterexamples to Question 4.10.

Remark 4.15. The proof of Proposition 3.5, in fact, provides an algorithm to decide whether a given closed, simply-connected spin 6-manifold M with torsion-free homology and $b_2(M) = 2$ can be constructed via an algebraic plumbing graph, see [19, Algorithm E.2].

4.4 | Manifolds obtained from algebraic plumbing graphs

In this section, we give examples of manifolds that can or cannot be obtained from an algebraic plumbing graph.

Given $p, q \in \mathbb{N}$ and a set \mathcal{B}_q containing oriented diffeomorphism classes of manifolds of dimension q , we define $\mathcal{T}_{p+q-1}(\mathcal{B}_q)$ as the set containing all diffeomorphism classes of manifolds M_G , where $G = (U, V, E, \pi, \delta)$ is a geometric plumbing graph with simply-connected connected components, so that $B_v \cong S^p$ and π_v is trivial for all $v \in V$, and $B_u \in \mathcal{B}_q$ for all $u \in U$.

We will consider the case where $p = 3$ and $q = 4$, and where \mathcal{B}_4 consists of all known examples of 4-manifolds that admit a core metric, that is,

$$\mathcal{B}_4 = \left\{ \#_{i=1}^k \varepsilon_i \mathbb{C}P^2 \mid k \in \mathbb{N}_0, \varepsilon_i \in \{\pm 1\} \right\}.$$

Then, $\mathcal{T}_6(\mathcal{B}_4)$ consists of all manifolds on which we can construct a core metric using Theorem 1.1 with all known examples of 4-manifolds that admit a core metric. By construction, we have $M_{\overline{G}} \in \mathcal{T}_6(\mathcal{B}_4)$ for any algebraic plumbing graph G with simply-connected connected components. We will now show that also the converse holds.

Proposition 4.16. *Let $M \in \mathcal{T}_6(\mathcal{B}_4)$. Then, there is an algebraic plumbing graph G so that $M \cong M_{\overline{G}}$.*

For the proof, we need the following lemma.

Lemma 4.17. *For $\alpha \in \mathbb{Z}$, let G be the reduced graph below.*

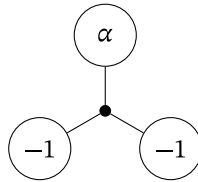

Then $M_{\overline{G}}$ is diffeomorphic to the total space of the linear S^2 -bundle over $\mathbb{C}P^2$ corresponding to $(\alpha, 1)$ in Remark 2.11.

Proof. The group H_G is generated by the elements $e_1 = u_1^0 - u_2^0$ and $e_2 = u_3^0 - u_2^0$, where we denote by u_1 the vertex labeled by α . Then

$$\begin{aligned} \mu_G(e_1, e_1, e_1) &= \alpha + 1, \\ \mu_G(e_1, e_1, e_2) &= 1, \\ \mu_G(e_1, e_2, e_2) &= 1, \\ \mu_G(e_2, e_2, e_2) &= 0, \\ p_G(e_1) &= 4(\alpha + 1), \\ p_G(e_2) &= 0. \end{aligned}$$

Now the claim follows from [20, Corollary 5.8] and Theorem 4.1. □

Proof of Proposition 4.16. Let G' be a geometric plumbing graph so that $M \cong M_{G'}$. We have that any linear sphere bundle over a connected sum of 4-manifolds is obtained by the fiber connected sum of bundles over each summand as the gluing area of the connected sum, which is diffeomorphic to S^3 , does not admit nontrivial vector bundles. Hence, we can apply Proposition 3.5 in reverse iteratively to split all base manifolds that are connected sums into their summands. In this way, we modify G' so that all B_u are given by S^4 or $\pm\mathbb{C}P^2$.

Further, by applying Proposition 3.2, we can achieve that $\delta(e) = 1$ for all $e \in E$. Now we turn G' into an algebraic plumbing graph G by reversing the construction in Subsection 4.2, except for vertices u for which π_u is an S^2 -bundle over $\pm\mathbb{C}P^2$ with spin total space, that is, those corresponding to $(\alpha, 1) \in \mathbb{Z} \times \{0, 1\}$ in Remark 2.11, as these are the only linear S^2 -bundles over S^4 and $\pm\mathbb{C}P^2$ that do not arise in the construction of Subsection 4.2. Every such vertex u gets replaced by a piece

of the form as in Lemma 4.17, multiplied by ± 1 , where all edges connected to u get connected to the vertex labeled by α . By using Corollary 3.15, we now obtain that $M_{\overline{G}}$ has the same invariants as M , hence they are diffeomorphic. \square

Remark 4.18. The bundles in Lemma 4.17, together with connected sums of S^2 -bundles over S^4 , are the only known infinite families of closed, simply-connected spin 6-manifolds M with $b_2(M) = 2$ that admit a metric of positive Ricci curvature, see [20, Theorem C and Subsection 5.1]. Hence, Proposition 4.12 and items (3) and (4) of Remark 4.14 yield an infinite number of new examples of such manifolds and therefore an infinite number of new examples of 6-manifolds with a metric of positive Ricci curvature and $b_2 = 2$. To the best of our knowledge, the corresponding manifolds in dimension $6k$, which are $(2k - 1)$ -connected, are also new examples of manifolds with a metric of positive Ricci curvature.

Remark 4.19. It is worth noting that not all closed, simply-connected 6-manifolds with torsion-free homology can be constructed via an algebraic plumbing graph. For graphs of rank 1, this directly follows from Proposition 3.3 together with Theorem 4.1. For graphs of rank 2, this can be seen by considering the normal forms of [22, Section 3.4]. This has been analyzed in detail in [19, Proposition 6.5.4].

Further, one can show that any manifold that is diffeomorphic to the total space of a linear S^{2k} -bundle over $S^{2k} \times S^{2k}$ cannot be constructed via an algebraic plumbing graph, see [19, Proposition 6.5.7]. These manifolds are of special interest as it is known that they admit metrics of positive Ricci curvature for all k and core metrics if $k \geq 2$. This shows that not all manifolds that admit a metric of positive Ricci curvature can be constructed via algebraic plumbing graphs.

Next, we consider homotopy $\mathbb{C}P^3$'s. A closed manifold is a *homotopy* $\mathbb{C}P^3$, if it is homotopy equivalent to $\mathbb{C}P^3$. In terms of invariants, a closed manifold M is a homotopy $\mathbb{C}P^3$ if and only if

- M is a simply-connected 6-manifold with torsion-free homology,
- $b_3(M) = 0$ and $b_2(M) = 1$,
- $\mu_M(x, x, x) = 1$ for a generator x of $H^2(M)$, and
- $w_2(M) = 0$.

This follows for example from the homotopy classification for simply-connected 6-manifolds by Zhubr [29]. We note that the homotopy classification given by Wall [28] and Jupp [13] is erroneous, cf. [29, 5.14] or [16, Remark 2]. It can also be seen directly as follows: Let M be a simply-connected manifold whose cohomology ring is isomorphic to that of $\mathbb{C}P^n$ and let $x \in H^2(M)$ be a generator. The element $x \in H^2(M)$ defines a map

$$f_x : M \rightarrow K(\mathbb{Z}, 2) = \mathbb{C}P^\infty$$

with the property that the induced map on cohomology maps a generator of $H^*(\mathbb{C}P^\infty)$ to x . By the cellular approximation theorem, we can assume that f_x is cellular, so the image is contained in $\mathbb{C}P^n \subseteq \mathbb{C}P^\infty$. Then $f_x : M \rightarrow \mathbb{C}P^n$ induces an isomorphism on cohomology and, since M is assumed to be simply-connected, it is therefore a homotopy equivalence by the Hurewicz theorem and Whitehead's theorem. Note that we did not use the assumption on w_2 . In fact, since Stiefel–Whitney classes are preserved under homotopy equivalences, it follows that $w_2(M)$ vanishes if and only if n is odd (alternatively, this can also be seen by using Wu classes).

From Theorem 4.1, it follows that there is an infinite family of homotopy $\mathbb{C}P^3$'s whose diffeomorphism types are distinguished by p_1 , which can take any value congruent to 4 mod 24 on the generator x . By Proposition 4.11, the only homotopy $\mathbb{C}P^3$ that can be constructed via an algebraic plumbing graph is the standard $\mathbb{C}P^3$ as only the graph $\textcircled{\pm 1}$, which defines the standard $\mathbb{C}P^3$, can produce the cohomology ring of $\mathbb{C}P^3$. However, we have the following result.

Proposition 4.20. *There is an infinite family M_i , $i \in \mathbb{N}_0$, of pairwise nondiffeomorphic homotopy $\mathbb{C}P^3$'s, such that for each $i \in \mathbb{N}_0$, there is a closed, simply-connected 6-manifold N_i so that $M_i \# N_i \in \mathcal{T}_6(\mathcal{B}_4)$. In particular, $M_i \# N_i$ admits a core metric.*

Proof. Let G be the graph

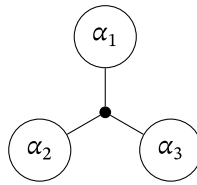

with

$$\alpha_1 = (2i + 1)(i + 1), \quad \alpha_2 = (2i + 1)i, \quad \alpha_3 = \frac{i(i + 1)}{2}.$$

Denote the vertices labeled by α_i by u_i . Then, a basis for H_G is given by $e_1 = u_1^0 + u_2^0 - 2u_3^0$, $e_2 = iu_1^0 + (i + 1)u_2^0 - (2i + 1)u_3^0$, and we have

$$\begin{aligned} \mu_G(x_1, x_1, x_1) &= 1, \\ \mu_G(x_1, x_1, x_2) &= 0, \\ \mu_G(x_1, x_2, x_2) &= 0, \\ \mu_G(x_2, x_2, x_2) &= \frac{i(i + 1)(2i + 1)}{2}, \\ p_G(x_1) &= 4 + 24 \frac{i(i + 1)}{2}, \\ p_G(x_2) &= 4 \frac{i(i + 1)(2i + 1)}{2} + 24 \frac{i(i + 1)(2i + 1)}{6}. \end{aligned}$$

Hence, $M_{\overline{G}}$ is diffeomorphic to $M_i \# N_i$ if we define M_i and N_i as the unique closed, oriented simply-connected spin 6-manifolds with

- $b_3(M_i) = b_3(N_i) = 0$,
- $b_2(M_i) = b_2(N_i) = 1$,
- $\mu_{M_i}(x, x, x) = 1$ for a generator x of $H^2(M_i)$,
- $p_1(M_i)(x) = 4 + 24 \frac{i(i+1)}{2}$,
- $\mu_{N_i}(y, y, y) = \frac{i(i+1)(2i+1)}{2}$ for a generator y of $H^2(N_i)$, and
- $p_1(N_i)(y) = 4 \frac{i(i+1)(2i+1)}{2} + 24 \frac{i(i+1)(2i+1)}{6}$.

The manifold M_i is a homotopy $\mathbb{C}P^3$, and for different values of i , we obtain different values for the divisibility of the first Pontryagin class; hence, all M_i are pairwise nondiffeomorphic. \square

Finally, we consider the question, if a given manifold M can be decomposed into a connected sum $M = M_1 \# M_2$, where $M_1, M_2 \not\cong \Sigma^{6k}$ for any homotopy sphere Σ^{6k} . To analyze this on the level of cohomology, let H be a finitely generated free abelian group with a symmetric trilinear form $\mu : H \times H \times H \rightarrow \mathbb{Z}$. Given a subspace $Y \subseteq H$, we say that Y is a direct summand in (H, μ) , if there is another subspace $Z \subseteq H$ such that $H = Y \oplus Z$ and

$$\mu(y_1, z_1, z_2) = \mu(z_1, y_1, z_2) = 0$$

for all $y_1, y_2 \in Y, z_1, z_2 \in Z$.

Lemma 4.21. *Let m be the rank of Y and let (y_1, \dots, y_m) be a basis of Y . If Y is a direct summand in (H, μ) , then for any basis (x_1, \dots, x_n) of H , the matrix*

$$\begin{pmatrix} \mu(x_1, x_1, y_1) & \cdots & \mu(x_1, x_n, y_1) & \cdots & \cdots & \mu(x_1, x_1, y_m) & \cdots & \mu(x_1, x_n, y_m) \\ \vdots & \ddots & \vdots & \cdots & \cdots & \vdots & \ddots & \vdots \\ \mu(x_n, x_1, y_1) & \cdots & \mu(x_n, x_n, y_1) & \cdots & \cdots & \mu(x_n, x_1, y_m) & \cdots & \mu(x_n, x_n, y_m) \end{pmatrix}$$

has rank at most m .

Proof. For each y_i , we have a symmetric bilinear form $\mu(\cdot, \cdot, y_i)$. Let A_i denote its matrix in the basis (x_1, \dots, x_n) , that is, the matrix we consider is given by

$$A = (A_1 | \dots | A_m).$$

Since Y is a direct summand, there exists a subspace $Z \subseteq H$ so that $H = Y \oplus Z$ and products between elements of Y and Z vanish. Let (z_1, \dots, z_{n-m}) be a basis of Z . Then a basis for H is given by $(y_1, \dots, y_m, z_1, \dots, z_{n-m})$. Let S denote the matrix that maps this basis to (x_1, \dots, x_n) . Then, define

$$A' = S^T (A_1 | \dots | A_m) \begin{pmatrix} S & 0 \\ & \ddots \\ 0 & S \end{pmatrix} = (A'_1 | \dots | A'_m),$$

where A'_i is the matrix of $\mu(\cdot, \cdot, y_i)$ in the basis $(y_1, \dots, y_m, z_1, \dots, z_{n-m})$. The matrix A' has rank at most m , since it has $(n - m)$ lines that vanish. Since A' and A are obtained from each other via invertible matrices, also A has rank at most m . \square

Proposition 4.22. *Let G be the graph*

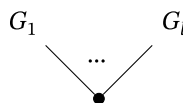

where each G_i is one of

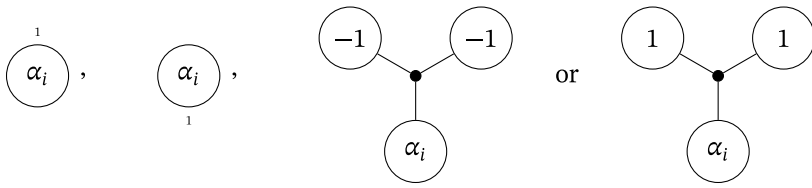

and the edge is connected to the vertex labeled by α_i . If $l \geq 2$, then $M_{G^k} \not\cong M_1 \# M_2$ for any $6k$ -dimensional manifolds M_1, M_2 that are not homotopy spheres.

Proof. Set $M = M_{G^k}$ and let M_1, M_2 be $6k$ -dimensional manifolds so that $M_1 \# M_2 \cong M$. Then, both $H^{2k}(M_1)$ and $H^{2k}(M_2)$ are direct summands in $(H^{2k}(M), \mu_M)$. By choosing the subspace of smaller rank, we obtain a direct summand Y in $(H^{2k}(M), \mu_M) \cong (H_G, \mu_G^k)$ of rank $m \leq \lfloor b_{2k}(M)/2 \rfloor = \lfloor (2l - 1)/2 \rfloor = l - 1$.

Fix i and let u_1 be the vertex labeled by α_i . If G_i consists of more than one vertex, denote the others by u_2 and u_3 . Then, either $x_i = u_1^0, x'_i = u_1^{\pm 1}$, or $x_i = u_1^0 - u_2^0, x'_i = u_3^0 - u_2^0$ is a basis of H_{G_i} . We define $\gamma_i = \mu_{G_i}^k(x_i, x'_i, x'_i)$ and $\beta_i = \mu_{G_i}^k(x_i, x_i, x'_i)/\gamma_i$, that is, we have the following possibilities:

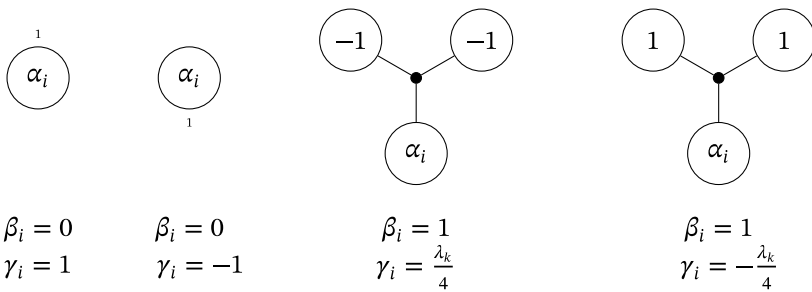

A basis for H_G is now given by $(x_1 - x_l, \dots, x_{l-1} - x_l, x'_1, \dots, x'_l)$. Let (y_1, \dots, y_m) be a basis of Y . Then, there exist $\lambda_{i,j}$ and $\mu_{i,j}$, so that

$$y_i = \sum_{j=1}^{l-1} \lambda_{i,j}(x_j - x_l) + \sum_{j=1}^l \mu_{i,j}x'_j.$$

Let $\lambda_{i,l} = -\sum_{j=1}^{l-1} \lambda_{i,j}$. Then, the matrix A_i in Lemma 4.21 is given as follows:

$$\begin{pmatrix} * & \dots & * & \gamma_1(\mu_{i,l} + \lambda_{i,l}\beta_1) & 0 & \dots & 0 & \dots & 0 & \dots & -\gamma_1(\mu_{i,l} + \beta_1\lambda_{i,l}) \\ * & \dots & * & 0 & 0 & \dots & 0 & \dots & 0 & \dots & 0 \\ \gamma_1(\mu_{i,l} + \lambda_{i,l}\beta_1) & 0 & 0 & \gamma_1\lambda_{i,l} & 0 & \dots & 0 & \dots & 0 & \dots & 0 \\ 0 & \dots & 0 & 0 & 0 & \dots & 0 & \dots & 0 & \dots & 0 \\ 0 & \dots & 0 & \gamma_{l-1}(\mu_{i,l-1} + \lambda_{i,l-1}\beta_{l-1}) & 0 & \dots & 0 & \dots & 0 & \dots & 0 \\ -\gamma_1(\mu_{i,l} + \beta_1\lambda_{i,l}) & \dots & -\gamma_1(\mu_{i,l} + \beta_1\lambda_{i,l}) & 0 & 0 & \dots & 0 & \dots & 0 & \dots & \gamma_1\lambda_{i,l} \end{pmatrix}.$$

By Lemma 4.21, the rank of A is at most $m \leq l - 1$. Let A_i^j denote the j th column of A_i . By considering A_i^l, \dots, A_i^{2l-1} , it follows that either all $\lambda_{i,j}$ vanish, or there is $j_0 \in \{l, \dots, 2l - 1\}$, so that $A_i^{j_0} = 0$ for all i . We first show that the second case implies the first one.

By symmetry reasons, we can assume that $j_0 = 2l - 1$, that is, $\lambda_{i,l} = \mu_{i,l} = 0$ for all i . In particular, $\sum_{j=1}^{l-1} \lambda_{i,j} = 0$. Now consider the matrix

$$(A_1^l | \dots | A_1^{2l-2} | \dots | A_m^l | \dots | A_m^{2l-2}),$$

which then also has rank at most m . By elementary row and column operations, we bring it into the following form:

$$A' = \left(\begin{array}{cccc|cccc|cccc} \mu_{1,1} & 0 & \dots & 0 & \mu_{2,1} & 0 & \dots & 0 & \mu_{m,1} & 0 & \dots & 0 \\ 0 & \dots & \dots & \dots & 0 & \dots & \dots & \dots & 0 & \dots & \dots & \dots \\ & & & 0 & & & & 0 & & & & 0 \\ 0 & \dots & 0 & \mu_{1,l-1} & 0 & \dots & 0 & \mu_{2,l-1} & 0 & \dots & 0 & \mu_{m,l-1} \\ \lambda_{1,1} & 0 & \dots & 0 & \lambda_{2,1} & 0 & \dots & 0 & \dots & \dots & \lambda_{m,1} & 0 & \dots & 0 \\ 0 & \dots & \dots & \dots & 0 & \dots & \dots & \dots & 0 & \dots & \dots & \dots & \dots & \dots \\ & & & & & & & & & & & & & & 0 \\ & & & & & & & & & & & & & & \lambda_{m,l-1} \\ 0 & \dots & \dots & 0 & 0 & \dots & \dots & 0 & 0 & \dots & \dots & 0 & \dots & 0 \end{array} \right).$$

Then, the vectors

$$w_i = \begin{pmatrix} \mu_{i,1} \\ \vdots \\ \mu_{i,l-1} \\ \lambda_{i,1} \\ \vdots \\ \lambda_{i,l-1} \\ 0 \end{pmatrix}$$

lie in the space generated by the columns of A' . Since $\mu_{i,l} = \lambda_{i,l} = 0$, and since (y_1, \dots, y_m) is a basis of Y , it follows that (w_1, \dots, w_m) is linearly independent. Hence, since A' has rank at most m , (w_1, \dots, w_m) is a basis (over \mathbb{Q}) of the space generated by the columns of A' . Thus, since $\sum_{j=1}^{l-1} \lambda_{i,j} = 0$, every $v = (v_1, \dots, v_{2l-1})$ in the space generated by the columns of A' satisfies

$$\sum_{i=l}^{2l-2} v_i = 0.$$

In particular, $\lambda_{i,j} = 0$ for all i, j .

Hence, we can assume that all $\lambda_{i,j}$ vanish. Then define

$$w'_i = \sum_{j=1}^{l-1} \frac{1}{\gamma_j} A_i^j = \begin{pmatrix} * \\ \vdots \\ \mu_{i,1} \\ \vdots \\ \mu_{i,l-1} \\ -(l-1)\mu_{i,l} \end{pmatrix}.$$

Since (y_1, \dots, y_m) is a basis of Y , the elements w'_1, \dots, w'_m are linearly independent and hence a basis over \mathbb{Q} of the space generated by the columns of A . But they also form a linearly independent set together with the w_i (which also lie in the space generated by the columns of A since $\lambda_{i,j} = 0$), which is a contradiction unless $m = 0$.

Thus, one of the M_i , say M_1 , has vanishing cohomology in degree $2k$, so $H^{2k}(M) = H^{2k}(M_2)$. By Corollary 2.13 and Theorem 3.12, any $x \in H^2(M)$ is nontrivial if and only if $x^k \in H^{2k}(M)$ is nontrivial and all other elements in $H^*(M)$ are obtained from powers of elements in $H^2(M)$ and multiplication by $a \in H^{2k}(M)$. Thus, $H^*(M_2) = H^*(M)$ and M_1 has nontrivial cohomology groups only in degrees 0 and $6k$. Hence, M_1 is a homology sphere and since it is simply-connected, it is therefore a homotopy sphere. □

Remark 4.23. Since there do not exist exotic spheres in dimensions 6 and 12, we actually obtain for $k = 1, 2$ that M_{G^k} does not split as a connected sum $M_1 \# M_2$ for any M_1, M_2 that are not standard spheres.

For the proof of Theorem B, we need the following lemma to conclude that we obtain new examples.

Lemma 4.24. *For any $n \in \mathbb{N}$, there exists a constant $C(n)$ so that any closed n -dimensional manifold M that has the structure of a homogeneous space, a biquotient, a cohomogeneity one manifold, or a Fano variety satisfies Gromov’s Betti number bound*

$$\sum_{i=0}^n b_i(M) \leq C(n).$$

Proof. Every homogeneous space and, more general, every biquotient admits a metric of nonnegative sectional curvature. This is well known and follows from the fact that for a compact Lie group G , any biinvariant metric has nonnegative sectional curvature and, by O’Neill’s formulas for Riemannian submersions, this property descends to any biquotient $G//H$. Further, by [24, Theorem A], any closed cohomogeneity one manifold admits a metric of almost nonnegative sectional curvature. Thus, for these spaces, the claim follows from Gromov’s Betti number theorem [11]. For Fano varieties, the claim follows from the fact that, by [8, Theorem 2.1], there exist only finitely many diffeomorphism types in each dimension. □

Proof of Theorem B. Let $M = M_{G^k}$ with G as in Proposition 4.22, where we choose each subgraph G_i to be spin, that is, one of the third or fourth option. Then, by Proposition 4.22, M does not split

nontrivially as a connected sum and we have that M is $(2k - 1)$ -connected with $b_{2k}(M) = 2l - 1$. Further, M admits a core metric by Theorem A and for l sufficiently large, it is not diffeomorphic to a homogeneous space, a biquotient, a cohomogeneity one manifold, or a Fano variety by Proposition 4.24.

To show that it is not diffeomorphic to the total space of a linear sphere bundle, note that, for every $\lambda_1, \lambda_2 \in \mathbb{Z}$, we have $\lambda_1 x_1 + \lambda_2 x_2 - (\lambda_1 + \lambda_2)x_3 \in H_G$ (where we use the notation x_i, x'_i as in the proof of Proposition 4.22). Hence, there exist $\lambda_1, \lambda_2 \in \mathbb{Z}$, with one of $\lambda_i \neq 0$, so that

$$p_G^k(\lambda_1 x_1 + \lambda_2 x_2 - (\lambda_1 + \lambda_2)x_3) = 0.$$

Then, for i with $\lambda_i \neq 0$, we have

$$\mu_G^k(\lambda_1 x_1 + \lambda_2 x_2 - (\lambda_1 + \lambda_2)x_3, x'_i, x'_i) = \lambda_i \gamma_i \neq 0.$$

Hence, if $p_G^k \neq 0$, then M is not diffeomorphic to the total space of a linear sphere bundle by Lemma 2.7.

To obtain a nonspin manifold, we can alternatively choose some of the G_i , say m , to be non-spin, that is, one of the first and second options. Then, M is merely simply-connected, apart from that the same conclusions hold as in the spin case, except that the fact that μ_G^k is nontrivial on $\ker p_G^k$ does not necessarily imply, that M is not diffeomorphic to the total space of a linear sphere bundles, as in this case, this follows only for linear S^{p-1} -bundles with $p \geq 2k + 1$. Hence, suppose that M is diffeomorphic to the total space E of a linear S^{p-1} -bundle with $1 < p \leq 2k$. We consider the Euler characteristic, which, by Corollary 2.6 and Theorem 3.12, is given by

$$\chi(M) = 2 + 2m(k - 1) + (l - 1 + m)(k + 1).$$

Since $\chi(M) > 0$, we have that p is odd by Lemma 2.7. If $k = 1$, this is a contradiction. If k is even, then $\chi(M)$ is odd for $m \equiv l \pmod{2}$, which is a contradiction by Lemma 2.7.

Finally, we need to determine when p_G^k vanishes. We have

$$\begin{aligned} p_G^k(x_i - x_l) &= \lambda_k(\alpha_i - \alpha_l) + \binom{2k + 1}{k}((1 - \beta_i)\gamma_i - (1 - \beta_l)\gamma_l) + 4(\beta_i\gamma_i - \beta_l\gamma_l) \\ &\equiv \binom{2k + 1}{k}(\gamma_i(1 - \beta_i) - \gamma_l(1 - \beta_l)) \pmod{\lambda_k} \end{aligned}$$

and $p_G^k(x'_i) = 0$. Hence, $p_G^k \equiv 0 \pmod{\lambda_k}$ if and only if $\beta_i = 0$ and $\gamma_i = \gamma_l$ for all i , or $\beta_i = 1$ for all i (note that $2\binom{2k+1}{k} < \lambda_k$ for $k \geq 3$ and $\lambda_1 = 4$ and $12 \mid \lambda_2$ by Remark 2.10). It follows that $p_G^k = 0$ if and only if $\beta_i = 0, \gamma_i = \gamma_l$ and $\alpha_i = \alpha_l$ for all i , or $\beta_i = 1$ and $\alpha_i + \gamma_i = \alpha_l + \gamma_l$ for all i .

Thus, we can, for example, set $\alpha_i = 0$ for all $i > 1$ and $\alpha_1 = j$ to define the manifold M_j for all $j > 1$. □

APPENDIX: ADJACENCY AND INCIDENCE MATRIX OF A DIRECTED GRAPH

In this appendix, we recall some well-known facts about the adjacency and incidence matrices of a directed graph. For convenience, we also include self-contained proofs.

Let R be a commutative ring and let $G = (V, E)$ be a directed graph, where $V = \{v_1, \dots, v_n\}$ is the set of vertices and $E = \{e_1, \dots, e_m\} \subseteq V \times V$ is the set of edges. The *incidence matrix* of G , denoted

by $Q(G)$, is the $n \times m$ -matrix with entries in R defined by

$$Q(G)_{ij} = \begin{cases} 1, & \text{if there is } k \text{ so that } e_j = (v_i, v_k), \\ -1, & \text{if there is } k \text{ so that } e_j = (v_k, v_i), \\ 0, & \text{else.} \end{cases}$$

Lemma A.1. *Suppose that G is connected. Then, the matrix $Q(G)^\top$ has kernel generated by $(1, \dots, 1)^\top$. In particular, $Q(G)$ has rank $n - 1$.*

Proof. Let $x \in R^n$ such that $x^\top Q(G) = 0$. Then, for every $e = (v_i, v_j) \in E$, we have $x_i - x_j = 0$, that is, $x_i = x_j$. Since G is connected, for any $v_i, v_j \in V$, there is a path between v_i and v_j , so $x_i = x_j$ for all $1 \leq i, j \leq n$. \square

Lemma A.2. *Suppose that the underlying undirected graph of G is simply-connected, that is, a tree. Then the matrix $Q(G)^\top$, when considered as a linear map $R^n \rightarrow R^m$, is surjective.*

Proof. Let $e_i \in E$. Since G is simply-connected, the edge e_i divides G into two subtrees. Let G' be the subtree from which e_i originates with root the vertex connected to e_i . Then define $x \in R^n$ by $x_j = 1$ whenever v_j is contained in G' and $x_j = 0$ otherwise. Then it follows that $Q(G)^\top x$ is the i th standard basis vector of R^m and hence $Q(G)^\top$ is surjective. \square

Now let $G = (U, V, E)$, be a bipartite graph, where $U = \{u_1, \dots, u_r\}$ and $V = \{v_1, \dots, v_s\}$ are the sets of vertices and $E \subseteq U \times V$ is the set of edges. Let $\delta : E \rightarrow \{\pm 1\}$ be a labeling of the edges. The *biadjacency matrix* of G , denoted by $B(G)$, is the $r \times s$ -matrix with entries in R defined by

$$B(G)_{ij} = \begin{cases} \delta(e), & e = (u_i, v_j) \in E, \\ 0, & \text{else.} \end{cases}$$

Lemma A.3. *Suppose that G is a tree so that no $v \in V$ is a leaf. Then, $B(G)$ has full rank.*

Proof. We show that $B(G)$, when considered as a linear map $R^s \rightarrow R^r$, is injective. Let $x \in R^s$ with $B(G)x = 0$ and let $u_i \in U$ be a leaf. Then there is a unique $v_j \in V$ so that $(u_i, v_j) \in E$, hence $x_j = 0$.

Now we remove all the leaves, which are vertices in U , and all $v \in V$ that turn into leaves by this procedure and get a subgraph G' that is again a tree and has no vertex in V as a leaf. For all those $v_j \in V$ that get removed, we already have $x_j = 0$. Hence, by removing these entries from x , we obtain a vector x' with $B(G')x' = 0$. Hence, by induction, it follows that $x = 0$. \square

Lemma A.4. *Suppose that G is a tree so that no $v \in V$ is a leaf. Then, the image of $B(G)$, when considered as a map $R^s \rightarrow R^r$, is a direct summand in R^r .*

Proof. We define a vertex in V , say v_1 , to be the root of G . For every vertex $v_j \in V$, we then pick a vertex $u_i \in U$ connected to v_j that has greater distance to v_1 than v_j . We set $f(j) = i$ and obtain a function $f : \{1, \dots, s\} \rightarrow \{1, \dots, r\}$. Since no vertex in V is a leaf, the function f is well defined and since G contains no cycle, the function f is injective. Denote by e_i the i th standard basis vector of

R^r and the union of the columns of $B(G)$ and the elements e_i with $i \notin \text{im}(f)$ by C . We will show that C is a basis of R^r .

Let $u_\ell \in U$. If $\ell \notin \text{im}(f)$, then e_ℓ is already contained in C . Otherwise let $j \in \{1, \dots, s\}$ such that $f(j) = \ell$. If $j = 1$, then the first column of $B(G)$ is a sum of elements in $(e_i)_{i \notin \text{im}(f)}$ and e_ℓ (after multiplying each element by ± 1), in particular, e_ℓ is a linear combination of elements in C . If $j > 1$, then the j th column of $B(G)$ is a sum of elements in $(e_i)_{i \notin \text{im}(f)}$, e_ℓ and an element e_k where u_k is the preceding vertex to v_j (and again each element is multiplied by ± 1). In particular, u_ℓ is a linear combination of elements in C and e_k . By induction, this shows that any e_ℓ is a linear combination of elements in C , so C is a generating set for R^r .

Since C has $r = \text{rank}(R^r)$ elements, it follows that C is a basis of R^r and R^r is the direct sum of the subspace generated by the columns of $B(G)$ and the subspaces generated by the elements e_i with $i \notin \text{im}(f)$. \square

ACKNOWLEDGMENTS

This article is based on the author's Ph.D. thesis written at the Karlsruhe Institute of Technology (KIT). The author would like to thank his supervisors Wilderich Tuschmann and Fernando Galaz-García for their support. The author would also like to thank them and Anand Dessai for helpful comments on an earlier version of this article and Manuel Krannich for helpful conversations on the homotopy groups of the orthogonal group. Finally, the author would like to thank the anonymous referee for their insightful comments.

The author acknowledges funding by the Deutsche Forschungsgemeinschaft (DFG, German Research Foundation) – 281869850 (RTG 2229).

Open access funding enabled and organized by Projekt DEAL.

JOURNAL INFORMATION

The *Journal of Topology* is wholly owned and managed by the London Mathematical Society, a not-for-profit Charity registered with the UK Charity Commission. All surplus income from its publishing programme is used to support mathematicians and mathematics research in the form of research grants, conference grants, prizes, initiatives for early career researchers and the promotion of mathematics.

ORCID

Philipp Reiser  <https://orcid.org/0000-0002-7997-7484>

REFERENCES

1. *Encyclopedic dictionary of mathematics. Vol. I–IV*, 2nd ed., MIT Press, Cambridge, MA, 1987. Translated from the Japanese, Edited by Kiyoshi Itô.
2. A. Borel and F. Hirzebruch, *Characteristic classes and homogeneous spaces. II*, Amer. J. Math. **81** (1959), 315–382, DOI [10.2307/2372747](https://doi.org/10.2307/2372747).
3. B. L. Burdick, *Metrics of positive Ricci curvature on connected sums: projective spaces, products, and plumbings*, ProQuest LLC, Ann Arbor, MI, 2019. Thesis (Ph.D.)–University of Oregon. http://gateway.proquest.com/openurl?url_ver=Z39.88-2004&rft_val_fmt=info:ofi/fmt:kev:mtx:dissertation&res_dat=xri:pqm&rft_dat=xri:pqdiss:13898429.
4. B. L. Burdick, *Ricci-positive metrics on connected sums of projective spaces*, Differential Geom. Appl. **62** (2019), 212–233, DOI [10.1016/j.difgeo.2018.11.005](https://doi.org/10.1016/j.difgeo.2018.11.005).
5. B. L. Burdick, *Metrics of positive Ricci curvature on the connected sums of products with arbitrarily many spheres*, Ann. Global Anal. Geom. **58** (2020), no. 4, 433–476, DOI [10.1007/s10455-020-09732-7](https://doi.org/10.1007/s10455-020-09732-7).

6. B. L. Burdick, *The space of positive ricci curvature metrics on spin manifolds*, arXiv e-prints, arXiv: 2009.06199, 2020.
7. D. Crowley and D. J. Wraith, *Positive Ricci curvature on highly connected manifolds*, J. Differential Geom. **106** (2017), no. 2, 187–243, DOI [10.4310/jdg/1497405625](https://doi.org/10.4310/jdg/1497405625).
8. T. de Fernex and C. D. Hacon, *Rigidity properties of Fano varieties*, Current developments in algebraic geometry, Math. Sci. Res. Inst. Publ., vol. 59, Cambridge University Press, Cambridge, 2012, pp. 113–127.
9. D. M. Davis and M. Mahowald, *The SO(n)-of-origin*, Forum Math. **1** (1989), no. 3, 239–250, DOI [10.1515/form.1989.1.239](https://doi.org/10.1515/form.1989.1.239).
10. M. Gromov and H. B. Lawson, Jr, *The classification of simply connected manifolds of positive scalar curvature*, Ann. of Math. (2) **111** (1980), no. 3, 423–434, DOI [10.2307/1971103](https://doi.org/10.2307/1971103).
11. M. Gromov, *Curvature, diameter and Betti numbers*, Comment. Math. Helv. **56** (1981), no. 2, 179–195, DOI [10.1007/BF02566208](https://doi.org/10.1007/BF02566208).
12. M. W. Hirsch, *Differential topology*, Graduate Texts in Mathematics, vol. 33, Springer, New York-Heidelberg, 1976.
13. P. E. Jupp, *Classification of certain 6-manifolds*, Proc. Cambridge Philos. Soc. **73** (1973), 293–300, DOI [10.1017/S0305004100076854](https://doi.org/10.1017/S0305004100076854).
14. W. S. Massey, *On the cohomology ring of a sphere bundle*, J. Math. Mech. **7** (1958), 265–289, DOI [10.1512/iumj.1958.7.57020](https://doi.org/10.1512/iumj.1958.7.57020).
15. J. W. Milnor and J. D. Stasheff, *Characteristic classes*, Annals of Mathematics Studies, vol. 76, Princeton University Press, Princeton, NJ; University of Tokyo Press, Tokyo, 1974.
16. Ch. Okonek and A. Van de Ven, *Cubic forms and complex 3-folds*, Enseign. Math. (2) **41** (1995), no. 3–4, 297–333.
17. R. S. Palais, *Natural operations on differential forms*, Trans. Amer. Math. Soc. **92** (1959), 125–141, DOI [10.2307/1993171](https://doi.org/10.2307/1993171).
18. G. Perelman, *Construction of manifolds of positive Ricci curvature with big volume and large Betti numbers*, Comparison geometry (Berkeley, CA, 1993–94), Math. Sci. Res. Inst. Publ., vol. 30, Cambridge University Press, Cambridge, 1997, pp. 157–163.
19. P. Reiser, *Generalized surgery on Riemannian manifolds of positive Ricci curvature*, Ph.D. thesis, Karlsruher Institut für Technologie (KIT), 2022. DOI [10.5445/IR/1000150280](https://doi.org/10.5445/IR/1000150280).
20. P. Reiser, *Generalized surgery on Riemannian manifolds of positive Ricci curvature*, Trans. Amer. Math. Soc. **376** (2023), no. 5, 3397–3418. DOI [10.1090/tran/8789](https://doi.org/10.1090/tran/8789).
21. A. Scharf, *Zur Faserung von Graphenmannigfaltigkeiten*, Math. Ann. **215** (1975), 35–45, DOI [10.1007/BF01351789](https://doi.org/10.1007/BF01351789).
22. A. Schmitt, *On the classification of certain 6-manifolds and applications to algebraic geometry*, Topology **36** (1997), no. 6, 1291–1315, DOI [10.1016/S0040-9383\(96\)00048-1](https://doi.org/10.1016/S0040-9383(96)00048-1).
23. J.-P. Serre, *Groupes d'homotopie et classes de groupes abéliens*, Ann. of Math. (2) **58** (1953), 258–294. DOI [10.2307/1969789](https://doi.org/10.2307/1969789).
24. L. J. Schwachhöfer and W. Tuschmann, *Curvature and cohomogeneity one*, Max Planck Institute for Mathematics in the Sciences Preprint Series, Preprint no. 62, 2001.
25. J.-P. Sha and D. Yang, *Positive Ricci curvature on the connected sums of $S^n \times S^m$* , J. Differential Geom. **33** (1991), no. 1, 127–137. <http://projecteuclid.org/euclid.jdg/1214446032>.
26. J.-P. Sha and D. Yang, *Positive Ricci curvature on compact simply connected 4-manifolds*, Differential geometry: Riemannian geometry (Los Angeles, CA, 1990), Part 3 of Proc. Sympos. Pure Math., vol. 54, Amer. Math. Soc., Providence, RI, 1993, pp. 529–538, DOI [10.1090/pspum/054.3/1216644](https://doi.org/10.1090/pspum/054.3/1216644).
27. E. Thomas, *On the cohomology of the real Grassmann complexes and the characteristic classes of n-plane bundles*, Trans. Amer. Math. Soc. **96** (1960), 67–89, DOI [10.2307/1993484](https://doi.org/10.2307/1993484).
28. C. T. C. Wall, *Classification problems in differential topology. V. On certain 6-manifolds*, Invent. Math. **1** (1966), 355–374; corrigendum, ibid. 2 (1966), 306, DOI [10.1007/BF01425407](https://doi.org/10.1007/BF01425407).
29. A. V. Zhubr, *Closed simply connected six-dimensional manifolds: proofs of classification theorems*, Algebra i Analiz **12** (2000), no. 4, 126–230.